

Rosefield Solar Farm

Outline Construction Traffic Management Plan (CTMP) (Tracked)

EN010158/APP/7.5 2
Revision 02
Deadline 1
~~August 2025~~ March 2026
Rosefield Energyfarm Limited

APFP Regulation 5(2)(q)
Planning Act 2008
Infrastructure Planning
(Applications: Prescribed Forms
and Procedure) Regulations 2009



Table of Contents

- Table of Contents 1**
- 1. Introduction 3**
 - 1.1. Purpose of the Plan.....3
 - 1.2. The Order Limits3
 - 1.3. The Proposed Development.....3
 - 1.4. Structure of this Plan5
 - 1.5. Legislation and Planning Policy.....5
- 2. Access Strategy 6**
 - 2.1. Construction Traffic.....6
 - 2.2. Abnormal Loads.....7
 - 2.3. Barred routes.....7
 - 2.4. Proposed operational and maintenance access strategy8
 - 2.5. Proposed decommissioning access strategy8
- 3. Access Arrangements and Permits 9**
 - 3.1. Access Junctions.....9
 - 3.2. Timing and Permitting9
 - 3.3. Road Closures.....10
 - 3.4. Road Reconstruction11
 - 3.5. Physical Works.....11
- 4. Proposed Traffic Management Measures..... 14**
 - 4.1. Traffic Management Group.....14
 - 4.2. Contractor Selection & CLOCS15
 - 4.3. General Measures17
 - 4.4. Road Signage18
 - 4.5. HGV Vehicle Requirements20
 - 4.6. Wear & Tear Agreement.....20
 - 4.7. Turning Facilities & Banksmen21
 - 4.8. On-site Parking.....21
 - 4.9. Staff Travel Plan22
 - 4.10. Non-motorised road users.....22
 - Pedestrians and cyclists.....22
 - Equestrians.....23
- 5. AIL Traffic Management Measures 25**
 - 5.1. AIL Movement Protocols25

5.3.	AIL Convoy Health & Safety Measures	28
5.4.	Emergency Contingency Plan	29
6.	On-Site Access Management Proposals	30
6.1.	General Measures	30
6.2.	Areas of Proposed Exclusion	31
6.3.	Proposed Temporary Diversions	31
6.4.	Path signage	31
6.5.	Crossing Point Details	31
7.	CTMP Management	33
7.1.	CTMP Management Measures	33
7.2.	Complaint Management	34
7.3.	Co-ordination with other Schemes	34
7.4.	Implementation of Measures	35
8.	Summary	37
	Annex 1: Road Improvement Plans and Access Junction Layouts	38
8.1.	References	41

1. Introduction

1.1. Purpose of the Plan

1.1.1. This Outline Construction Traffic Management Plan (CTMP) has been prepared on behalf of Rosefield Energyfarm Limited ('the Applicant') to review the construction transport access management in relation to the Development Consent Order (DCO) Application for the construction and operation (including maintenance) of Rosefield Solar Farm (hereafter referred to as the 'Proposed Development').

1.1.1.1.2. This document has been updated at Deadline 1 in response to comments from Buckinghamshire Council. References to other application documents have not been updated from the original submission. Please refer to the [Guide to the Application \[EN010158/APP/1.2.6\]](#) for the list of current versions of documents.

1.2. The Order Limits

1.2.1. The extent of the Order Limits are shown in **Location, Order Limits and Grid Coordinate Plans [EN010158/APP/2.1]** and the Proposed Development is described in full in **ES Volume 1, Chapter 3: Proposed Development Description [EN010158/APP/6.1]** and shown spatially on the **Works Plans [EN010158/APP/2.3]**.

1.3. The Proposed Development

1.3.1. The Proposed Development comprises the construction, operation (including maintenance), and decommissioning of Solar photovoltaic ('PV') development and energy storage, together with associated infrastructure and an underground cable connection to the existing National Grid East Claydon Substation.

1.3.2. The Proposed Development will include a generating station with a total exporting capacity exceeding 50 megawatts ('MW'). The agreed grid connection for the Proposed Development will allow the export and import of up to 500 MW of electricity to the grid.

1.3.3. The location of the Proposed Development is shown on **ES Volume 3, Figure 1.1: Location Plan [EN010158/APP/6.3]**. The Proposed Development will be located within the Order Limits (the land shown on the **Works Plans [EN010158/APP/2.3]** within which the Proposed Development can be carried out). The Order Limits plan is provided as **ES Volume 3, Figure 1.2: Order Limits [EN010158/APP/6.3]**. Land within the Order Limits is known as the 'Site'.

1.3.4. The principal components of the Proposed Development include:

- Solar PV development consisting of:
 - Ground mounted Solar PV generating station. The generating station will include Solar PV modules and mounting structures; and
 - Balance of Solar System (BoSS) which comprises: Inverters, Transformers, Switchgear and Combiner Boxes.
- A project substation (the 'Rosefield Substation') compound which may include Transformers, Switchgear, reactive power compensation bays, disconnectors, circuit breakers, busbars, control equipment, lightning surge arrestors, building(s) including office, control, functions, material storage, welfare facilities, firewalls and a security cabin and parking as well as wider monitoring and maintenance equipment. The buildings within the compound may also include roof-mounted solar panels and/or rain and/or grey water harvesting and recycling systems;
- 400kV Grid Connection Corridor to connect the Rosefield Substation and National Grid East Claydon Substation;
- A Main Collector Compound and two Satellite Collector Compounds comprising: Switchgear, Transformers, ancillary equipment, and operation, maintenance and welfare facilities and security cabins. The buildings and security cabins across these compounds may also include roof-mounted solar panels and/or rain and/or grey water harvesting and recycling systems;
- Battery Energy Storage System (BESS) compound including batteries and associated Inverters, Transformers, Switchgear and ancillary equipment and their containers, office/control/welfare buildings, enclosures, fencing and acoustic fencing, monitoring systems, air conditioning, electrical cables, fire safety infrastructure, and operation and maintenance security facilities. The buildings across these compounds may also include roof-mounted solar panels and/or rain and/or grey water harvesting and recycling systems;
- Cabling to connect the Solar PV modules and the BESS to the Satellite and Main Collector Compounds, the Main Collector Compound to the Rosefield Substation, and the Rosefield Substation to the National Grid East Claydon Substation;
- Ancillary infrastructure works including: boundary treatment, security equipment, lighting, fencing, landscaping, internal access tracks, works to facilitate vehicular access, earthing devices, earthworks, surface water management, and any other works identified as necessary to enable the Proposed Development;
- Green and blue infrastructure, recreation and amenity works including: amenity improvements;

- Site-wide operational monitoring and security equipment; and
- Highways infrastructure improvements and safety works including, where necessary: minor junction improvement works, road widening, passing places and works to facilitate vehicular access to the Site.

1.4. Structure of this Plan

1.4.1. Following this introduction, the Outline CTMP is structured as follows:

- Access Strategy;
- Access Arrangements and Permits;
- Proposed Traffic Management Measures;
- All Traffic Management Measures;
- Onsite Access Management Measures;
- CTMP Management; and
- Summary.

1.5. Legislation and Planning Policy

1.5.1. Consideration has been given to national and local policy and guidance relevant to this assessment. The policy and guidance documents considered within this assessment are as follows:

- National Policy Statement (NPS) for Energy (EN-1);
- Design Manual for Roads & Bridges (DMRB);
- Planning Practice Guidance “Travel Plans, Transport Assessments and Statements”;
- National Policy Statement for Renewable Energy Infrastructure (NPS EN-3) (2023);
- Buckinghamshire Council, Highways Development Management Guidance, 2018;
- Vale of Aylesbury Local Plan (VALP) 2013 – 2033 (Adopted September 2021); and
- Buckinghamshire Council, Local Transport Plan 4, 2018.

2. Access Strategy

2.1. Construction Traffic

- 2.1.1. All construction traffic, with the sole exception of Abnormal Indivisible Loads (AIL) is proposed to approach the Site from the A41, located to the south of the Proposed Development. Deliveries for construction materials will be made by Heavy Goods Vehicle (HGV) and Light Goods Vehicles (LGV).
- 2.1.2. Access from the A41 will be taken from South Station Road/Dews Way, Snake Lane/Fiddlers Field and Claydon Road. The proposed construction access route is illustrated in **Figure 1** (in blue) from the M40 corridor.
- 2.1.3. Construction traffic will originate from across the study area road network, with all traffic bypassing Bicester to the south.

Figure 1: Proposed Access Strategy

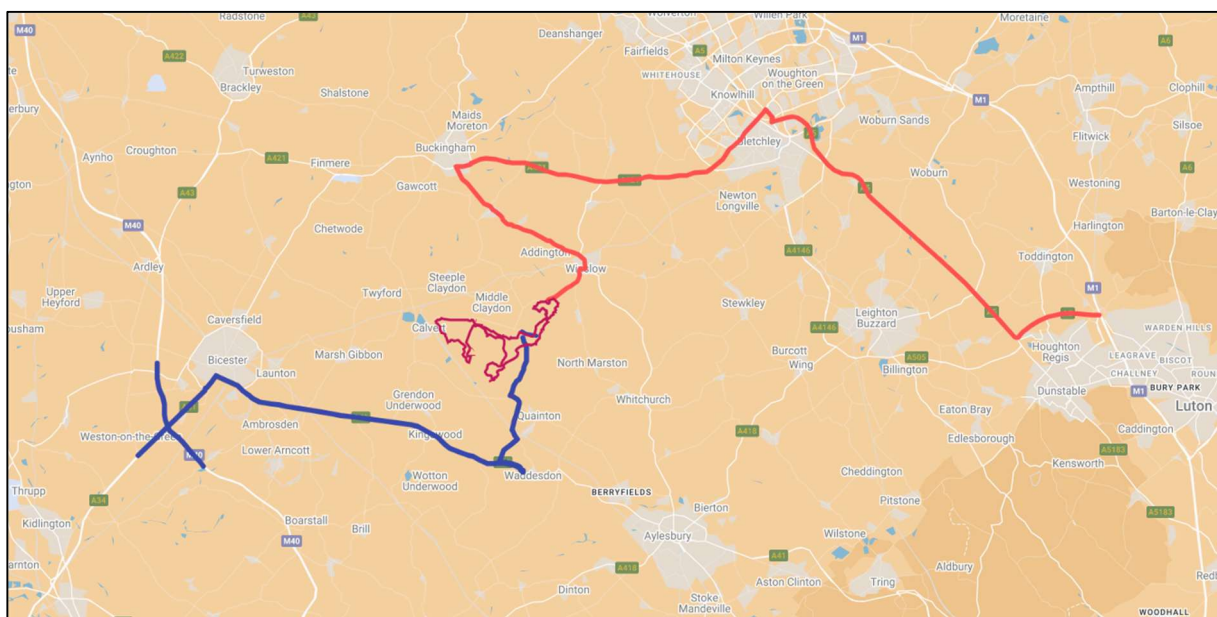

- 2.1.4. A principal access junction is to be built on Claydon Road, providing access to Parcels 1, 1a, 2 and 3 via a network of upgraded and new private access tracks.
- 2.1.5. Access to Parcel 3 will be taken from the south from a new junction on Granborough Road. This will be used by all construction traffic, with the sole exception of AIL traffic. AIL traffic is unable to use the A41 corridor due to a low rail bridge (to the north of Blackthorn). As such, the National Highways High and Heavy Load route from Winslow, specifically designated to access the National Grid East Claydon Substation, is to be used.

2.1.6. It is expected that AIL traffic associated with the transport of Transformer components will commence from the M1 corridor and will proceed to the Site via Milton Keynes, Buckingham and Winslow. The AIL route is illustrated in red in **Figure 1**.

2.2. Abnormal Loads

2.2.1. As detailed above, AIL traffic will travel through to the Site using the National Highways High and Heavy Load route from Winslow.

2.2.2. It is expected that AIL traffic associated with the transport of Transformer components will commence from the M1 corridor and will proceed to the Site via the following route:

- Loads will depart the M1 at Junction 11a;
- Loads will join the A5 and will bypass Dunstable before turning north on the A5;
- Loads will depart the A5 at the Redmoor Roundabout and will join the A421 Grafton Street northbound;
- At the junction of Grafton Street and Standing Way, loads will turn left and will proceed on the A421 Standing Way towards Buckingham;
- At the A421/A413 Roundabout in Buckingham, loads will turn left and will proceed southbound towards Winslow;
- In Winslow, loads will proceed southbound on High Street before turning right onto Vicarage Way;
- At the roundabout of Vicarage Way/Burleys Road, loads will turn left and will continue south of Burleys Road/Granborough Road;
- To the south of Winslow, loads will turn right onto East Claydon Road; and
- Loads will continue westbound on East Claydon Road, with the Site access junction potentially located either to the west or east of the existing National Grid East Claydon substation.

2.2.3. A detailed Route Survey of the access route is being undertaken and will be provided within **Appendix 15.1: Transport Assessment [EN010158/APP/6.4]**.

2.3. Barred routes

2.3.1. HGV traffic will not be allowed to travel through or access the Site passing through the following settlements:

- Botolph Claydon;
- East Claydon;
- Calvert;

- Steeple Claydon;
- Granborough;
- Quainton;
- Grendon Underwood;
- Edgcott;
- Marsh Gibbon; and
- Twyford.

2.3.2. The access routes through these settlements are not considered suitable for construction traffic and traffic will be regulated and controlled to ensure that these routes are not used. Further details of the control measures are provided in later sections of this plan.

2.3.3. AIL traffic can only proceed on the route set in the BE16 Special Order and Movement Orders issued by National Highways. In addition, all AIL loads are to be escorted by the Police and a civilian escort.

2.4. Proposed operational and maintenance access strategy

2.4.1. During the operational phase of the Proposed Development, it is anticipated that the trip generation associated with the maintenance will be minimal and that occasional access by LGV or 4x4 vehicles will be required.

2.5. Proposed decommissioning access strategy

2.5.1. At the end of the operational life of the Proposed Development, the Solar PV modules, BESS and all associated above ground equipment will be completely removed in line with a Decommissioning Environmental Management Plan (DEMP) to be approved by the relevant authorities prior to the Site being restored.

2.5.2. At this stage, it is not possible to accurately forecast the traffic impacts during the decommissioning phase, as projections of the baseline data into the future will not be accurate.

2.5.3. The levels of traffic associated with the decommissioning of the Proposed Development will be less than that during construction since some of the below ground elements will be left in situ and the internal access tracks may be retained for use by the landowners, as detailed in a future Decommissioning Statement.

2.5.4. To protect future stakeholders, it is proposed that a Decommissioning Traffic Management Plan (DTMP) is prepared prior to decommissioning works commencing and that this is secured via a DCO requirement.

3. Access Arrangements and Permits

3.1. Access Junctions

3.1.1. Access to the Proposed Development will be taken from two principal access junctions:

- Access to Parcels 1, 1a and 2 will be taken from a proposed new priority junction located on Claydon Road. This will provide access to the whole of the Site to the west of Claydon Road and
- Access to Parcel 3 will be taken via a new priority junction on Granborough Road. Construction access would be taken via Parcel 2 before accessing Granborough Road.

3.1.2. Both access junctions will be permanent and will be used throughout the lifetime of the Proposed Development.

3.1.2.3.1.3. No construction traffic will be permitted to travel east on Granborough Road to minimise interactions with local agricultural traffic and livestock crossings on the public road. The Applicant will work with local agricultural interests to facilitate the safe crossing of Granborough Road in the immediate vicinity of the access junction for livestock movements. -Full details will be provided in the detailed Construction Traffic Management Plan(s).

3.1.3.3.1.4. A temporary AIL access is proposed on East Claydon Road and will only be used by AIL traffic and escort vehicles. Once AIL deliveries are complete, the access track would not be used for general access.

3.1.4.3.1.5. Vegetation within the visibility splays will be trimmed to ensure sufficient sight lines for vehicles using the access junctions.

3.1.5.3.1.6. The access junctions will be signed to clearly indicate the point of access to the Site. Signage will also be located on the Site access road directing all traffic to proceed back onto the A41 using the route used to access the Site. An indicative signage strategy to signpost traffic to the approved route is provided in Annex 1 and proposes to use temporary black and yellow direction signage placed at strategic locations. The final design and location of the signs will be approved by Buckinghamshire Council prior to installation.

3.1.6.3.1.7. The access junction will be constructed to ensure that access along Claydon Road is not curtailed during the construction of the access junction. The Site Manager will implement appropriate measures, to ensure that there will be no verge parking by staff working at the Site.

3.2. Timing and Permitting

3.2.1. The indicative construction traffic programme indicates that construction will occur on a five and half day week, for a 30-month construction period. Construction deliveries and loading/unloading during this period will be

restricted to between the hours of 08:00-18:00 on Monday to Friday and 08:00-13:00 on Saturday. These hours will be secured by the draft DCO through the **Outline Construction Environmental Management Plan (CEMP) [EN010158/APP/7.2]**.

- 3.2.2. Wherever possible, HGV deliveries will avoid school opening and closing times during term time so as not to disrupt journeys to and from school. Term times and hours for East Claydon School, Quanton CoE Combined School, Furze Down School, Sir Thomas Freemantle School and Grendon Underwood Combined Schools will be obtained and advised to the Principal Contractor.
- 3.2.3. The timing of AIL convoy movements will be confirmed with the Police prior to deliveries commencing. The Police have previously advised for other projects that their preference is for loads to depart ports in the early evening to avoid peak traffic flows.
- 3.2.4. The Principal Contractor will liaise with Buckinghamshire Council (BC) to prepare a diary for local community events such as village fetes, farmer's markets, etc. Where possible, HGV traffic flows will avoid moving on these days.
- 3.2.5. Consultation on the timings of movements will also be undertaken with the HS2 Transport Officer and other developers to coordinate haulage operations that may use the access route during the construction period in order to minimise the cumulative impact on communities and road users.
- 3.2.5-3.2.6. [The Applicant will endeavour to hold monthly engagement meetings with HS2 to discuss construction traffic management matters and issues as necessary, post determination.](#)
- 3.2.6-3.2.7. The implementation of the access junction works and any associated mitigation works on the public road network required to allow access for the AIL and HGV deliveries will be subject to a technical approval process. These applications will be prepared following consent.
- 3.2.7-3.2.8. The BE16 abnormal load permits and movement orders will be submitted using National Highways ESDAL (Electronic Service Delivery for Abnormal Loads) system. Permits and orders relating to these will be obtained by the haulier undertaking the transport of AIL components.

3.3. Road Closures

- 3.3.1. No public roads will need to be closed solely as a result of the activities associated with the construction of the Proposed Development.
- 3.3.2. Lane closures will be required to construct the access junctions in a safe and efficient manner. One lane will be coned off and controlled by traffic signals when the junctions are being constructed.

- 3.3.3. These works will be temporary in nature and short-lived. They will not exceed 50 metres (m) in length and will not result in full road closures, diversion or significant delays.
- 3.3.4. As soon as the junctions are complete, the traffic signals and lane restrictions will be removed. The areas indicated for lane closures are shown on the **Traffic Regulation Plans [EN010158/APP/2.5]**.

3.4. Road Reconstruction

- 3.4.1. The current condition of Snake Lane/Fiddlers Field (early 2025) is exceptionally poor.
- 3.4.2. The road surface and foundation has failed throughout the length of the road. This has been caused by inadequate long-term maintenance, the diversion of HGV traffic due to the weak bridge at the Buckinghamshire Railway Centre and an increase in traffic flows associated with the closure of Station Road as part of the HS2 works.

3.4.3. The road currently requires reconstruction works. Should the road be in the existing condition when the Proposed Development is proposed to commence construction, then the Applicant will agree to undertake a road improvement scheme with Buckinghamshire Council to have the road rebuilt~~Should the road be in the existing condition when the Proposed Development is proposed to commence construction, then the Applicant will agree a road improvement fund with Buckinghamshire Council to have the road rebuilt.~~

3.4.3.3.4.4. Where possible and subject to approval from Buckinghamshire Council, the proposed road works to Snake Lane/Fiddlers Field, would be undertaken outwith the Summer school holiday period, so as not to adversely affect access to Hogshaw Farm and Wildlife Park.

3.4.4.3.4.5. A temporary road closure of Snake Lane/Fiddlers Field may be required during the reconstruction works (resurfacing in part or full) and the appropriate traffic management will be made. Any works on Snake Lane/Fiddlers Field will only take place prior to works on the Proposed Development commencing and would be considered to be part of the wider scheme pre-commencement works.

3.5. Physical Works

- 3.5.1. To ensure the safety of all road users and to assist with the safe delivery of materials, it is proposed to undertake road improvements works on the existing road network.
- 3.5.2. The main focus for this work will be on Granborough Road where the road width is insufficient for passing traffic. BC have requested that passing places are required on this road.
- 3.5.3. To cater for new passing places, four road widening areas are proposed and these are illustrated in **Annex 12**.

- 3.5.4. The passing areas generally provide 7m long tapers and allow for a 6m wide passing area. The passing places are 28m long and sufficient to allow an articulated HGV and a rigid HGV to wait as traffic passes them. The tapers are also long enough to cater for a car each, in addition to the HGV provision.
- 3.5.5. The double bend in the road will be widened to 7m to allow for greater forward visibility and to allow two articulated HGV to pass in safety.
- 3.5.6. The proposed works on Granborough Road are all located within the existing verge and ecological surveys have reviewed the proposed areas.
- 3.5.7. Further works are proposed on Claydon Road, to the east of Shipton Lee. A narrowing of the road will be widened to allow two traffic to pass unimpeded. A drawing illustrating this is provided in **Annex 4-2** along with swept path drawings of the road junctions on either side of this section to illustrate the movements.
- 3.5.8. The road enhancements would be constructed as permanent features for long term benefit to road users. Six months prior to the completion of construction works, the Applicant will engage with Buckinghamshire Council to confirm if the works are to be retained or removed. The final construction detail will be agreed with Buckinghamshire Council along with a decision if the works will be temporary for the construction phase or permanent works~~The road enhancements could be constructed as permanent features for long term benefit to road users. The final construction detail will be agreed with BC along with a decision if the works will be temporary for the construction phase or permanent works.~~
- 3.5.9. Prior to any construction works being undertaken within the limits of road adoption, the detailed design of these works must be submitted to the appropriate highway authority for approval. These submissions will include:
- A programme for the works, details of the construction method and traffic management requirements;
 - A detailed design pack of drawings and specifications detailing the works and any service / utility works that may need to be accommodated, informed by additional surveys including topographical surveys and additional speed survey data;
 - The necessary health and safety information required under the Construction, (Design & Management) Regulations, or their equivalent at the point of submission;
 - Details of the proposed contractor, including their insurance provisions;
 - If required by the local road authorities, a Road Safety Audit (RSA) to a combined Stage 1 and Stage 2 standard;
 - Details of any necessary road signage and road markings; and

- Details of any proposed remediation proposals should the works not be permanent.

3.5.10. The Applicant will reimburse the highway authorities for the technical approval process at the time the applications are made, in line with costs for similar Section 278 or Section 184 applications made under the Highways Act 1980. The detailed Construction Traffic Management Plan(s) will detail the exact process for these technical approvals.

3.5.8-3.5.11. Except as otherwise provided for in the Development Consent Order, any application for the written consent from the Highway Authority in relation to a Temporary Traffic Regulation Order (TTRO) will follow the procedure required by the Highway Authority at the time of application and will include full details of the proposed TTRO for inclusion in a 'roadworks bulletin' to be issued by the Highway Authority to relevant stakeholders which shall include the dates and times, locations and diversions, and contact numbers for the TTRO. Should any changes to these details be required post consent, the Highway Authority will be informed.

4. Proposed Traffic Management Measures

4.1. Traffic Management Group

- 4.1.1. The traffic management proposals in this plan will be provided to the Principal Contractor and they will be required to abide by these regulations as part of their commercial contracts with the Applicant. Failure to follow the traffic management measures proposed will be a non-compliance matter and could result in contractors being subject to penalties and individual sanctions.
- 4.1.2. To assist with general traffic management during the construction period, it is proposed that a Traffic Management Group (a potential subgroup of the Community Liaison Group) be formed to help advise of progress, issues and to feedback public comments. The suggested structure of this group will likely include the following:
- Local Road Manager from BC;
 - Local ward elected members;
 - A representative from each of the neighbouring Parish Councils;
 - A representative from the Police;
 - The Site Manager;
 - The CTMP Co-ordinator; and
 - A senior member from the Applicant's development team.
- 4.1.3. This subgroup of the Community Liaison Group will help co-ordinate works and provide a robust conduit for information and issues that may arise. It is suggested that it will meet as a minimum, every two months during the construction period, although specific construction activities may warrant changes in frequency over that time.
- 4.1.4. Pages with information about the construction of the Proposed Development Farm will be available on the Rosefield Solar Farm website. These will be updated throughout the construction period. If visitors to the Site are unable to find the answer to their question on the webpages, an email address will be provided on the Rosefield Solar Farm website to contact the Applicant. A telephone number for the CTMP Co-ordinator will be published during operational hours to resolve any traffic management problems that occur and these calls will be logged and reported to the Applicant on a weekly basis to monitor the situation.
- 4.1.5. All contractors will be monitored through regular spot-checks to ensure they follow the approved access route. Access routes identified will be clearly defined in all sub-contracts and signposted.

- 4.1.6. The Site access junctions will be kept clear at all times during construction and will be monitored by on site staff to ensure vehicles do not attempt to use the area for parking.
- 4.1.7. Use of a visible vehicle identification system for regular bulk delivery HGV traffic will be employed to ensure compliance with the agreed route and driver behaviour standards. The system will feature a large print number attached to the front, sides and rear of vehicles and will be unique to that HGV. This will allow the public to identify any rogue vehicles to the Site office for easy recognition and review. The visible identifier will be mandatory and required for trips to and from the construction Site.
- 4.1.8. To help enforce good behaviour, the Applicant will require regular HGV traffic to have GPS trackers fitted and will also arrange spot checks and tachograph inspections. These will help the Applicant enforce and provide evidence of any issues that may occur, so that actions can be undertaken and the public informed.
- 4.1.9. The Applicant will also create a protocol for working with local businesses to ensure the construction traffic does not interfere with deliveries or normal business traffic wherever possible.
- 4.1.10. The following measures will be provided to assist in managing traffic across the study area road network.

4.2. Contractor Selection & CLOCS

- 4.2.1. The Principal Contractor working on the Site will be required to adhere to the Considerate Constructors Scheme (CCS) and Construction Logistics and Community Safety (CLOCS) best practice guidance. This will be a mandatory requirement and failure to adhere will be a contractual matter.
- 4.2.2. The Principal Contractor will be required to ensure that all subcontractors are compliant to CLOCS principals. Regular audits by the Applicant will be undertaken to monitor compliance and require changes, if necessary.
- 4.2.3. CLOCS is a national standard that requires all stakeholders in construction to take responsibility for health & safety beyond construction Site boundaries. It demands collaborative action to prevent collisions between vehicles servicing construction projects and vulnerable road users.
- 4.2.4. The CLOCS standards require the following from all key partners working on the Proposed Development:
The developer shall:
 - Specify in tender and contract documents for all stakeholders to comply to the CLOCS Standard;
 - Ensure the project team develops and implements a suitable and sufficient CLP (Construction Logistics Plan);
 - Ensure effective monitoring of compliance to the CLOCS Standard;

- Obtain and monitor the contractor's action plan to address all identified issues and non-compliances; and
- Ensure that all collisions that result in harm (and near-miss incidents) that occur on journeys associated with the project are quickly investigated and actions taken to prevent recurrence.

The Principal Contractor shall:

- Ensure the project's potential impact on the community has been properly risk-assessed;
- Develop and/or implement the agreed CLP and ensure it remains suitable and sufficient;
- Procure Site and fleet operations that comply to the requirements of the CLOCS Standard;
- Ensure Site arrangements enable the safest fleet operations including but not limited to, 'last mile' routing, level access/egress, stable loading/unloading areas, effective delivery management systems and competent Site access traffic marshals;
- Ensure effective and efficient Site access gate checks of HGV and their drivers to ensure they always comply to the CLOCS Standard. Non-compliances must be immediately risk-assessed, appropriately mitigated and addressed through procurement processes;
- Ensure effective independent monitoring of the project's compliance with the CLOCS Standard is undertaken approximately every 6 months and appropriate action taken to address non-compliance; and
- Review information on all collisions that result in harm (and near-miss incidents) that occur on journeys associated with the project and ensure they are quickly investigated and actions taken to prevent recurrence.

Vehicle operators (above 3.5 tonnes) working at the Site shall:

- Ensure all journeys meet the requirements described as Silver in the Fleet Operator Recognition Scheme (FORS) Standard (by addressing key management, driver, vehicle and operations issues);
- Provides acceptable evidence of compliance as defined/specified by each procurer through formal accreditation through FORS or equivalent; and
- Amongst other issues it:
 - Provides evidence of a quality fleet operation;
 - Helps with selection of the most effective safety equipment;
 - Ensures drivers receive appropriate supplementary training;

- Requires the collection and reporting of collision data to inform ‘lessons to be learned’ – reporting to Clients/Principal Contractors were procured to do so; and
- Reduces risk to protect drivers and commercial reputation provides competitive advantage when bidding for work and opportunity to influence client procurement.

4.2.5. The use of CLOCS will help protect all road users from harm, both within and outside of the Proposed Development.

4.3. General Measures

4.3.1. Wherever reasonably possible, it is proposed to use local suppliers such as quarries and concrete works to help minimise traffic levels on the network. Upon selection of the Principal Contractor, wider area routing information (routes to join the A41) will be made available and final numbers of traffic movements confirmed.

4.3.2. The following measures will be implemented through the detailed CTMP during the construction phase:

- Contractual requirement in the Balance of Plant (BoP) contract that contractors will only use the agreed access route;
- Direction signage signposting traffic on the agreed access route;
- Identification numbers on HGVs and vans to allow easy recognition. These to be of a unique design and to be installed on the sides and rear of all HGVs accessing the Site, for journeys to and from the Site;
- Providing the public with details of how to report use of unapproved routes or driving issues of concern;
- Using GPS trackers to allow the monitoring of all frequent bulk material delivery HGV movements;
- Setting out Site staff disciplinary measures for those who ignore the agreed access route and enforcing these throughout the construction period;
- All regular bulk delivery HGV and full time Site vehicles will feature “white noise” reversing warning devices to reduce noise disruption when on Site;
- All materials delivery lorries (dry materials) will be sheeted to reduce dust and stop spillage on public roads;
- Specific training and disciplinary measures will be established to ensure the highest standards are maintained to prevent construction vehicles from carrying mud and debris onto the carriageway;

- Wheel cleaning facilities will be established at the Site entrances. A road sweeper will also be provided at Site to ensure that the public road near the Site access junctions is kept clean;
- A 30 miles per hour (mph) speed limit will apply to all HGV deliveries being made to Site on the route from the A41;
- Site induction for all staff instructing them on what route to Site they can use to enter and exit the Site and obtaining their acknowledgement that there is only one approved access route for construction traffic. The induction will include:
 - A tool box talk safety briefing;
 - The need for appropriate care and speed control;
 - A briefing on driver speed reduction agreements (to slow Site traffic at sensitive locations through towns and villages on the route); and
 - Identification of the required access routes and access junction operation and the controls to ensure no departure from these routes.
- Pollution reduction measures including the following:
 - Requiring traffic on site to switch off when stationary;
 - Ensuring that contractors use plant and vehicles that meet or exceed the latest emission standards;
 - Promote the use of sustainable fuels where possible and use electric vehicles wherever possible to reduce emissions; and
 - Promote travel planning to help reduce private car access to an absolute minimum.

4.4. Information to other Parties

4.4.1. Regular updates on traffic management issues will be issued to other parties with an interest in the proposed construction access route including, but not limited to, the National Trust at Claydon House, the Buckinghamshire Railway Centre and Hogshaw Farm, for their information.

4.4.2. Events organised by these parties will be noted, and if possible, specific traffic management measures could be introduced to avoid potential issue.

4.4.3. All of these parties will have the opportunity to raise specific concerns, if and when they arise, with the detailed Construction Traffic Management Plan(s) Co-ordinator.

4.4.4.5. Road Signage

4.4.1.4.5.1. A junction signage strategy will be prepared and agreed with BC prior to works commencing. The strategy will include the following:

- Direction signage to ensure vehicles keep to the approved route from the A41;
- Site access signage to advise other road users of increased movements at the junction;
- Chapter 8 (Traffic Signs Manual) “Slow Down” signage along the access route from the A41; and
- ALL specific signage.

4.4.2.4.5.2. Regular maintenance will be undertaken at the sign locations to keep the plates clean and to ensure that verge vegetation does not obscure them.

4.4.3.4.5.3. In addition to the statutory road signage noted around the Site access junctions, further information signage will be provided to assist road users especially during ALL deliveries. Advance warning signs will be installed at the following locations on the road network:

- On the A421 and A413 at locations agreed with the BC;
- Within Winslow; and
- On East Claydon Road between East Claydon and Winslow.

4.4.4.4.5.4. Information signage could be installed to help assist drivers and an example is illustrated in **Figure 2**. Flip up panels (shown in grey) will be used to mask over days where convoys will not be operating. When no convoys are moving, the sign will be bagged over by the Traffic Management contractor.

4.4.5.4.5.5. This signage will assist in helping improve driver information and allow other road users to consider alternative routes or times for their journey (where such options exist).

Figure 2: Example Information Sign

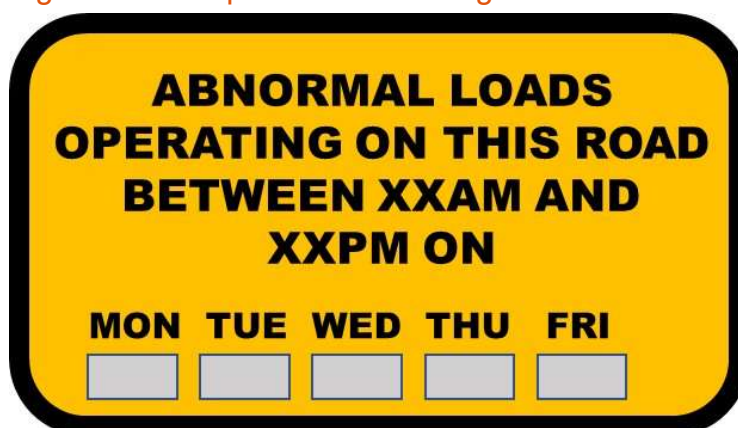

4.5.4.6. HGV Vehicle Requirements

4.5.1.4.6.1. To ensure the highest standards of safety for all road users and contractors, all HGVs frequently arriving at Site shall be required to comply with the following standards:

- Prominent hazard warning signage, advising other road users not to get too close to the vehicle;
- A camera system for blind spots;
- Audible or visual front nearside driver alerts;
- Audible nearside left turn warning;
- Reversing external warning; and
- A Mobile Digital Recover capable of storing two weeks' worth of data, which may be viewed by the Principal Contractor on a 'just cause' basis.

4.6.4.7. Wear & Tear Agreement

4.6.1.4.7.1. A legal agreement with BC is suggested to cover the cost of abnormal wear and tear on the road network between the A41 and the Site access junctions. This will be agreed with BC following the granting of the Development Consent Order.

4.6.2.4.7.2. The wear and tear agreement will address concerns about possible damage to the public road, verges and structures. It will be based upon condition surveys of the road to ensure that the condition of the road does not deteriorate solely as a result of the construction works.

4.6.3.4.7.3. Video footage of the pre-construction phase condition of the proposed access route will be recorded to provide a baseline of the state of the road prior to any construction work commencing. This High Definition (HD) baseline review will inform any change in the road condition during the construction stage of the Proposed Development as it notes the existing condition of the road surface and features and details current condition.

4.6.4.4.7.4. The condition survey will feature still images from the survey and will measure specific defects to monitor their progression. Locations of points will be accurately logged using a GPS tracker.

4.6.5.4.7.5. To agree the current condition of the road, the condition survey will be agreed with the Council prior to construction works commencing.

4.6.6.4.7.6. Any immediate necessary repairs will be coordinated with the Council. Any damage caused by traffic associated with the Proposed Development, during the construction period that will be hazardous to public traffic, will be repaired immediately.

4.6.7.4.7.7. During construction activities, a general road wear and tear review will be undertaken with Buckinghamshire Council every three months during construction. Interim reviews will be undertaken by the Principal Contractor on a weekly basis and the progress reports issued to the Applicant.

4.6.8.4.7.8. Any damage to road infrastructure caused directly by construction traffic will be made good, and street furniture that is removed on a temporary basis will be fully reinstated.

4.6.9.4.7.9. There will be a regular road edge review and any debris and mud will be removed from the public carriageway to keep the road clean and safe during the initial months of construction activity, until the construction junction and immediate access track works are complete.

4.6.10.4.7.10. Where defects occur on the road network leading from the A41, the Principal Contractor will ensure that they maintain a stockpile of road repair material on Site to undertake repair works quickly and efficiently, when authorised by Buckinghamshire Council to undertake interventions.

4.6.11.4.7.11. Upon completion of construction activities, a follow-on condition review will be undertaken and a defects list prepared. Works required to reinstate the road back to its original condition will be undertaken at the Applicant's expense following a review by Buckinghamshire Council.

4.6.12.4.7.12. Where there are cases where defects will need to be addressed quickly, the contractor can have arrangements in place to respond to serious and significant defects within two hours during normal working hours and within four hours outside normal working hours.

4.7.4.8. Turning Facilities & Banksman

4.7.1.4.8.1. For safety reasons both on site and for other road users, the Site has been designed so all vehicles can enter and exit the Site in a forward gear. No vehicle shall reverse onto unmanaged public roads and shall enter/exit the Site using forward gear only.

4.7.2.4.8.2. A banksman will be provided at the Site access to help guide traffic within the Site and to ensure health and safety access for the Site. The banksman will be in radio contact with the wider Site compound to advise of movements to and from the Site.

4.7.3.4.8.3. Upon completion of construction works, a gate will be provided on the access junctions. The gate will be set back from the public road to ensure that future maintenance HGV vehicles can stop at the gate without blocking the public road.

4.8.4.9. On-site Parking

4.8.1.4.9.1. Once operational, parking will only be permitted in designated areas and all operatives will be required to reverse park at all times. An appropriate number of standard parking spaces and one disabled parking

space will be provided adjacent to the control building. Rosefield Substation will have a small number of parking spaces adjacent to its control building. The proposed parking provisions for the whole of the Substation Site have been developed from operational experience of similar sized projects.

4.8.2.4.9.2. During the construction works, parking will be provided in designated areas and all Site operatives and visitors will be subject to Site rules. No parking will be permitted on the public road verges.

4.9.4.10. Staff Travel Plan

4.9.1.4.10.1. A Staff Travel Plan will be developed in the [detailed Construction Traffic Management Plan\(s\)](#), to manage the arrival and departure profile of construction staff and to encourage sustainable modes of transport, especially car-sharing. A package of measures will include:

- Provision of public transport information to access where staff will be resident so there is no need for non-local staff to bring cars to the wider area;
- Staff bus service for transport of Site staff from Bicester and Aylesbury, with pick ups from the mainline rail stations, accommodation/hotel areas and park & rides sites;
- Promotion of a car sharing scheme; and
- Car parking management.

4.9.2.4.10.2. The Staff Travel Plan will be developed to reduce the number of single occupancy car journeys to and from the Site during construction and will minimise traffic on the local road network.

4.9.3.4.10.3. The Staff Travel Plan will be administered by the CTMP Co-ordinator and will be a contractual requirement as part of the Principal Contractor's contract with the Applicant.

4.10.4. The Staff Travel Plan will include targets to reduce car use during construction and will apply to Site visitors, where it is practical to do so.

4.9.4.4.10.5. [All vehicles accessing the Site need to be pre-booked for access to the sSite. Vehicles that are not pre-booked will be refused access.](#)

4.10.4.11. Non-motorised road users

Pedestrians and cyclists

4.10.1.4.11.1. There are no footways or street lighting on either side of the roads leading from the A41 to the Site access junctions. Nevertheless, consideration must be given to pedestrians and cyclists alike as the road network leading from the A41 will continue to carry local and HGV traffic associated with agricultural and other uses throughout the construction phase.

4.10.2.4.11.2. The Principal Contractor will ensure that speed limits are always adhered to by their drivers and associated subcontractors, through spot checks, tachograph reviews and the use of GPS on regular HGV traffic. Advisory speed limits will be installed on Claydon Road and Granborough Road in advance of the Site access to help reduce speeds and make drivers aware of cyclists, hikers and other vulnerable road users.

4.10.3.4.11.3. Signage will be installed on the Site exit to remind drivers of local speed limits and advise drivers of the potential presence of pedestrians and cyclists in the area. This will also be emphasised in the weekly tool box talks during the construction phase.

Equestrians

4.10.4.4.11.4. The British Horse Society has made recommendations on the interactions between HGV traffic and horses. Horses are normally nervous of large vehicles, particularly when they do not often meet them. Horses are flight animals and will run away in panic if really frightened. Riders will do all they can to prevent this but, should it happen, it could cause a serious accident for other road users, as well as for the horse and rider.

4.10.5.4.11.5. The main factors causing fear in horses in this situation are:

- Something approaching them, which is unfamiliar and intimidating;
- A large moving object, especially if it is noisy;
- Lack of space between the horse and the vehicle;
- The sound of air brakes; and
- Anxiety on the part of the rider.

4.10.6.4.11.6. The British Horse Society recommends the following actions that will be included in the Site training for all HGV staff:

- On seeing riders approaching, drivers must slow down and stop, minimising the sound of air brakes, wherever possible;
- If the horse still shows signs of nervousness while approaching the vehicle, the engine should be shut down (if it is safe to do so);
- The vehicle should not move off until the riders are well clear of the back of the HGV;
- If drivers are wishing to overtake riders, please approach slowly or even stop in order to give riders time to find a gateway or lay by where they can take refuge and create sufficient space between the horse and the vehicle. Because of the position of their eyes, horses are very aware of things coming up behind them; and
- All drivers delivering to the Site must be patient. Riders will be doing their best to reassure their horses while often feeling a high degree of anxiety themselves.

4.10.7.4.11.7. Training for staff working at the Site will advise staff on how to react properly if encountering equestrians on the access route.

5. AIL Traffic Management Measures

5.1. AIL Movement Protocols

5.1.1. All AIL movements will be undertaken in line with the UK Government's "Water Preferred" Policy at the time of delivery. All relevant AIL applications for permits and movement orders will be made by the selected haulier, prior to deliveries commencing in line with the relevant legislation.

5.1.1-5.1.2. AIL movements must be escorted by the Police. Given the size of the proposed loads, it is expected that at least three civilian escorts and a minimum of two police escort vehicles are likely to be required (exact requirement will be confirmed with the police). The likely deployment of escorts will be as follows:

- The first police escort vehicle will be the advance escort and will be located sufficiently ahead of the convoy, to advise the convoy in good time of traffic stoppages, constraints and oncoming hazards;
- The second police escort and first civilian escort will provide support to the first escort at junction closures and will be located at the front of the lead vehicle; and
- The second civilian escort will be located behind the last vehicle to protect the rear of the convoy and ensure that following vehicles do not attempt dangerous overtaking manoeuvres. A third civilian escort will be located at this location to provide support at the rear of the convoy and to prevent dangerous overtaking.

5.1.2-5.1.3. Before the convoys depart the Port of Entry (PoE) (to be determined post the granting of the DCO) the Lead Driver should check weather and traffic conditions and ensure this information is included within the daily toolbox talks.

5.1.3-5.1.4. Within the route, there are locations where general traffic flows will need to be stopped to allow the safe manoeuvre of the loads. In these circumstances the advance escorts will ensure that the traffic is stopped before the convoys enter the affected section. The advance escorts will confirm through radio contact that the area is clear and safe for transit. Should general traffic fail to observe the request to stop, the advance escort will advise the convoy to immediately halt and will then proceed to remove the rogue traffic. The convoy must not start without approval from the advance escort.

5.1.4-5.1.5. In areas where the load is likely to, or is close to straddling the centre line, the advance escort should be positioned to give advance warning to the convoy such that evasive action can be taken. In constrained areas and other locations where verges are potentially soft, the drivers must exercise care to ensure the trailer wheels do not leave the road surface as this may result in adverse load stability conditions.

5.1.5-5.1.6. Urban areas along the route (Milton Keynes, Buckingham and Winslow) pose different challenges for the abnormal loads. Whilst the vehicle speeds will be less than those in the rural sections of the route, there are more potential conflicts with other road users to be aware of. These include:

- Pedestrians and cyclists;
- Local vehicular traffic;
- Parked vehicles;
- Side junctions; and
- Street furniture.

5.1.6-5.1.7. Within urban areas, the convoy escorts will need to be aware of all road and footway users at turn sections within the route. At these locations there is potential for load over-sail and reference to the swept path assessment drawings is considered essential to identify these areas. It is important to note that only the Police have the power to request that vehicles and pedestrians move.

5.1.7-5.1.8. Within urban areas there is a higher chance of parked vehicles along the route and a possibility that parked cars will restrict available road width. Whilst these areas will not impede the loads, they do create a further zone where the load drivers and escorts will need to take care of conflicts that include restricted road widths, car doors opening and pedestrians crossing the road between parked vehicles.

5.1.8-5.1.9. Information relating to AIL movements will be provided directly to residents living in the immediate vicinity of the access route. Information on the movement of the abnormal load convoys will also be provided to local media outlets by the Principal Contractor (or their appointed AIL delivery contractors) to help assist the public. Information will be provided to local newspapers and radio stations, which will include:

- Bucks Herald;
- Buckinghamshire Examiner;
- Bucks Free Press;
- Buckingham and Winslow Advertiser;
- Buckinghamshire Live;
- One MK;
- BBC Three Counties Radio;
- Bucks Radio; and
- Heart FM.

5.1.9.5.1.10. The project website will also be used to help advise of movements. Information will relate to expected vehicle movements on the route. It is hoped that this level of information will make residents aware of convoy movements and help reduce any conflicts.

5.3. AIL Convoy Health & Safety Measures

- 5.2.1. All staff working on the project will be inducted before entering the Site. This will be undertaken prior to the commencement of AIL movements.
- 5.2.2. A daily tool box talk for all convoy staff will be held at the start of each working day and carried out by the appointed Transport Co-ordinator or Appointed Lead Driver. A detailed record of the talk should be kept and filed once the convoy has arrived at the Site.
- 5.2.3. The tool box talks will cover a minimum of the following matters:
- The current version of the CTMP to be carried by all convoy vehicles;
 - Identification of any updates since the previous version of the CTMP;
 - Requirement to have a CB radio (fixed or portable), with fully charged batteries;
 - Anticipated transport restrictions in each section of the route;
 - Driver instructions on incident reporting;
 - Driver instructions on trailer steering methodology, and availability of assistance;
 - Instructions on areas requiring traffic stoppage, and methodology for convoy passing through these areas;
 - The welfare arrangements for drivers;
 - A summary of the predicted weather, traffic and road conditions; and
 - Any questions on the contingency plans.
- 5.2.4. Each of the convoy vehicles must be suitably equipped with hazard warning devices to warn all other road users. All the tractor, trailer and escort vehicles operating on the project must have the following:
- Tractor units to have beacon bars on the roof and 3M reflective markings on both sides;
 - All vehicle warning signage to be in English;
 - Trailer units to have amber beacons on the rear with 3M reflective markings on both sides;
 - All escort vehicles will have beacon bars on the roof, with 360 degree motion for all round visibility, and 3M reflective markings;
 - Fire extinguisher and first aid kit; and
 - Certified cargo lashing straps are to be used at all times. Certification must be carried and made available for inspection, kept within the cab.

- 5.2.5. All hazard warning equipment must be checked and cleaned at the start of each day. Additional cleaning of the warning equipment may be required throughout the day and must be undertaken when required.
- 5.2.6. All relevant personnel must have the appropriate Personal Protective Equipment (PPE). All PPE clothing must be 'CE' marked to show it meets current standards and should be appropriate for use in trunk road situations (i.e. must be full coats with reflective bands on the arms).

5.4. Emergency Contingency Plan

- 5.3.1. To ensure access for emergency service vehicles, a coordination protocol will be established with the blue light emergency services. As the AIL convoys are escorted by the Police, the Police will be aware of potential access issues for ambulances and fire service vehicles and can take appropriate action on the route to pull to the side of the road or mount a verge to allow emergency vehicles past.
- 5.3.2. Convoys will not enter Winslow if a blue light emergency had been raised and will wait until the emergency situation along the road had been attended to.
- 5.3.3. The civilian escort vehicles will carry equipment to make running repairs to vehicles in the unlikely event of a breakdown. Further spares and equipment can also be based at the Site for faster responses in case of mechanical issues.
- 5.3.4. The haulier will establish contracts with local suppliers to attend to any punctures and tyre issues, to minimise any stoppage time on the route.

6. On-Site Access Management Proposals

6.1. General Measures

- 6.1.1. During the construction phase, construction traffic has the potential to interact with walkers, cyclists and equestrians using the existing footpath network. Various measures are proposed to assist with the safety of all path users.
- 6.1.2. The Applicant will ensure that the Principal Contractor provides the following during the construction phase:
- That any footpath which has had its surface disturbed will be remediated upon completion of the relevant construction activity (i.e. at a crossing point);
 - People will not be asked to avoid using a route or area when there is no safety related reason to do so;
 - Warning signs will be removed promptly when the relevant hazard has ceased;
 - Vehicular access gates may be locked for management reasons including the control of unauthorised vehicles for example but will only be locked where a side pedestrian side gate is provided. Where construction activities present a potential danger to pedestrians/other users a temporary diversion or re-routing will be advised in the interests of health and safety;
 - All pedestrian gates to be provided on Site will meet BS 5709 and shall have a minimum width of 1.525m to ensure equine access; and
 - Electric wires or barbed wire will not be used on the Site.
- 6.1.3. During construction activities, the Construction Contractor operatives will act and behave in a responsible manner when asking people to avoid construction activity risks. They will:
- Display signs notifying path users of any upcoming diversion option, prior to any diversion taking place;
 - Notifying path users that a diversion option is in place by displaying signage at the Site of the diversion itself;
 - Take precautions, such as asking people to avoid using a particular route or area, or to avoid doing a particular activity where there are more serious or less obvious hazards to their safety;
 - Keep any precautions to the minimum area and duration required to safeguard people's safety;
 - Notify the public about any precautions at all access points;
 - Not deliberately obstruct a footpath; and

- Not obstruct or hinder people from exercising access rights, either by physically obstructing access or by otherwise discouraging or intimidating them.

6.1.4. In addition, all construction operatives will be required to understand the requirements of onsite access rights at their induction. Failure to observe these may result in their removal from Site.

6.2. Areas of Proposed Exclusion

6.2.1. Construction operations such as track construction, cabling and fencing works will require exclusion areas being set out in the areas surrounding these works.

6.2.2. Should there be a need to provide a short-term closure of a footway, the Applicant will advise BC's Access Officer and will request the closure. Such closures will be signposted entrances to the affected footpath(s).

6.3. Proposed Temporary Diversions

6.3.1. Diversions to footpaths will only be required during track and cable trench construction activities.

6.3.2. During construction, it will be necessary to form the access track across existing footpath alignments. During these operations, the footpath will be subject to a minor diversion around the advancing head of the access track works. This will ensure access for footpath users in safety and diversion signs will be provided.

6.3.3. The diversion works will be 2m in width and will provide a 10m approximate diversion to allow the access track works to slightly pass the crossing point. Ducting will be provided to allow cabling works at a later stage that will not disrupt footpath access.

6.3.4. Upon completion of the track works, a footpath crossing point will be installed, where required. Further details are provided in **Section 6.5**.

6.4. Path signage

6.4.1. Signage to inform footpath users will be provided on stakes at strategic locations on the footpath network. This will include at the entry points to the Site, at any crossing points and at strategic points as a reminder.

6.4.2. All direction signs will be green and will have text height of 75mm to allow easy viewing.

6.4.3. In addition, the Principal Contractor will post a plan of the Site at the entrance points to the Site each week highlighting areas where works are ongoing to help advise path users.

6.5. Crossing Point Details

- 6.5.1. Where a footpath crosses the access tracks, a crossing point will be formed. This will include the following:
- “Access Track Crossing Ahead” signage for the footpath, on either side of the crossing, located at least 20m in advance of the crossing;
 - “Crossing Point” and “Please look in both directions” signage for the footpath on either side of the crossing;
 - A 2m wide chicane to ensure that cyclists slow down for the crossing to ensure the safety of all users;
 - “Crossing Ahead” and “Slow Down, 10 mph” signs on access tracks, located 100m and 50m in advance of the crossing on both directions; and
 - “Give Priority to Footpath Users” on the Site access track.
- 6.5.2. Reflective pole markers will be provided in advance of the crossing point to aid identification for access track users.
- 6.5.3. A visibility splay in the access track verge will be created so that footpath users have good visibility in either direction at each crossing point. This will be maintained throughout the construction phase.
- 6.5.4. All signage will be kept and maintained during the operational phase of the Proposed Development.
- 6.5.5. Livestock crossing points will be provided on the access track network at locations discussed and agreed with the relevant farmers. The livestock crossings will be controlled by the use of gates on the private access tracks to separate construction traffic and staff from livestock movements. All parties will work together to ensure the safe and efficient operation of livestock movements, so that agricultural business interests are respected during the construction phase.
- 6.5.4-6.5.6. The crossing points will be designed through discussions with the relevant farmers to ensure the crossings are of a sufficient width to enable the safe transit of livestock.

7. CTMP Management

7.1. CTMP Management Measures

- 7.1.1. The key to the successful delivery of the CTMP will be the implementation, monitoring, review and enforcement of the plan. Without the implementation at the start of the project, the CTMP will not be effective and it will need to be carefully monitored and reviewed as the project progresses.
- 7.1.2. Key to this will be the requirement in the Principal Contractor contract for the CTMP to be included as a deliverable measure within the contract, given the same status as the physical elements of the solar farm Site itself.
- 7.1.3. The contractor will be obliged to follow the CTMP and will face penalties if this is not undertaken, which could result in disciplinary actions and ultimately being removed from the contract. This requirement will be placed upon all subcontractors working on Site and will be communicated via the various contracts and through induction processes and tool box talks.
- 7.1.4. A CTMP Co-ordinator will be appointed on Site and will be responsible for the implementation of the CTMP and the monitoring of its effectiveness. The Co-ordinator will also be the communication point for all external queries raised by members of the public, whilst also being the on site lead for the plan.
- 7.1.5. Prior to works commencing, the Co-ordinator will agree with Buckinghamshire Council the CTMP measures to be deployed on Site and will hold an initial meeting of the Traffic Management Group(a potential subgroup of the Community Liaison Group) to advise all relevant groups of the start of works on Site, expected traffic levels and what measures are to be deployed.
- 7.1.6. During the construction phase, a log of public and staff comments relating to the operation of the CTMP will be kept and the Co-ordinator will be required to brief the Applicant on the issues raised and what measures are to be undertaken to address comments.
- 7.1.7. The Co-ordinator will chair the Transport Management Group and will provide updates and information for onward dissemination to the local community including local media queries and press releases for items such as AIL movements.
- 7.1.8. Quarterly reviews of the CTMP will be undertaken and where modifications are required, these will be discussed with the Council and Police and agreed before changes occur on the ground. Updates will then be advised to the Traffic Management Group.

- 7.1.9. Regular road condition reviews and sign maintenance will also be undertaken to ensure that the physical measures are safe and working efficiently.
- 7.1.10. The engagement of stakeholders and local representatives is considered key in ensuring that the increase in traffic levels associated with the construction phase can be carefully, efficiently and sensitively managed to the benefit all parties concerned.

7.2. Complaint Management

- 7.2.1. When complaints are received, the CTMP Co-ordinator will record the incident using a database logging system. A receipt of the complaint will be emailed to the person making the complaint. The receipt will include details of the formal response and how the complaint can be escalated, if required.
- 7.2.2. The Co-ordinator will then investigate the incident and will discuss what actions need to occur with the Applicant and Site Manager.
- 7.2.3. To ensure public faith in the reporting system, the Co-ordinator will agree a response timetable as part of the detailed CTMP. The following suggested response times are suggested:
- Receipt of original complaint: Within 2 working days of the complaint being received;
 - Investigation time: Within 3 working days of receipt of the complaint (assuming no requirement to involve/consult with third parties);
 - Corrective Action Decision: Within 1 working day of the completion of the investigation (assuming no requirement to involve third parties); and
 - Response: To be issued to the complainant within 2 working days of the Corrective Action Decision.
- 7.2.4. It is of the utmost importance that the public know that their complaint will be investigated, actioned and that they are informed of what actions are being taken.
- 7.2.5. The time taken to respond, the number of complaints raised and a review of the corrective actions will be a standing agenda item of the Traffic Management Group to ensure that the public can be assured that their issues are being considered and dealt with.

7.3. Co-ordination with other Schemes

- 7.3.1. The CTMP Co-ordinator will liaise with other significant developments in the area to ensure that works and deliveries can be co-ordinated between other schemes in the area.

7.3.1-7.3.2. The Applicant and HS2 will endeavour to hold monthly engagement meetings following determination to discuss construction traffic management matters and issues.

7.3.2-7.3.3. Where common traffic management issues can be agreed, these will be implemented once to avoid the need for repetition and delay to existing road users, where it is possible to do so.

7.4. Implementation of Measures

7.3.3-7.3.4. The detailed CTMP which will be implemented during the construction phase by the Principal Contractor will describe the traffic management, safety, control and review measures that will be used. The detailed CTMP will include details of the following measures, where appropriate:

- A programme of traffic management measures to be implemented and details of traffic management proposals for the works on or adjacent to public roads;
- Drawings showing traffic management layouts, signing and apparatus to be implemented, including proposed routes for pedestrians, equestrians and cyclists;
- Measures to provide for the safety of traffic, the public and construction staff during traffic management works and temporary traffic control measures;
- Measures to ensure that the maintenance and condition of public roads, cycleways and PRoW do not deteriorate due to the construction traffic, including monitoring arrangements with local highway authorities;
- Procedures to be followed for the temporary or permanent closure or diversion of roads or accesses; including details of required notice periods;
- Existing pedestrian, equestrian and cyclist routes;
- A Staff Travel Plan to allow staff to use shuttle bus and vehicle sharing to access the works site(s);
- Details of onsite parking arrangements for site staff and site visitors;
- Temporary and permanent access to the works;
- Permitted access routes for construction traffic;
- Monitoring requirements in relation to the plan;
- Details of phasing of works;
- Phasing plan for site and offsite works, including a general construction works programme;
- A list of roads which may be used by construction traffic in the vicinity of the site including any restrictions to construction traffic on these routes;

- The name and contact details of the Contractor's traffic safety and control officer and information and advice for the public regarding ways to raise complaints or request information;
- A register of applications for consents associated with temporary traffic management measures; and
- Block and layout plans of the compounds which will comprise:
 - Access/egress arrangements including visibility splays onto the public road;
 - Turning movements within the site especially for articulated HGV traffic to ensure that all vehicles enter and depart the site in forward gear;
 - Internal parking arrangements for staff and visitors;
 - Storage of materials and waste on site; and
 - Pedestrian / circulation routes within the compound.

8. Summary

- 8.1.1. To assist with the management of construction traffic on the access routes, this Outline CTMP has been prepared. This Outline document is a live document and will be subject to alteration and enhancement in the run up to and throughout the construction phase of the Proposed Development. This will ensure that the document is relevant and addresses issues quickly and efficiently.
- 8.1.2. The outline CTMP sets out the approved access route to the Proposed Development, how this will be managed and the steps that will be undertaken to ensure that the roads leading to Site are well managed to the benefit of all road users.
- 8.1.3. The ~~finalised-detailed~~ [Construction Traffic Management Plan\(s\)](#) will be secured via the DCO and will be partly self-enforcing through spot checks, contractual controls and information provision.
- 8.1.4. Should the Proposed Development be consented, the Applicant will work with Buckinghamshire Council to further develop the document and ensure that the road network can function in a safe and efficient manner for all road users.

Annex 1: Road Improvement Plans and Access Junction Layouts
Indicative Construction Direction Signage

Indicative Construction Direction Signage Plan

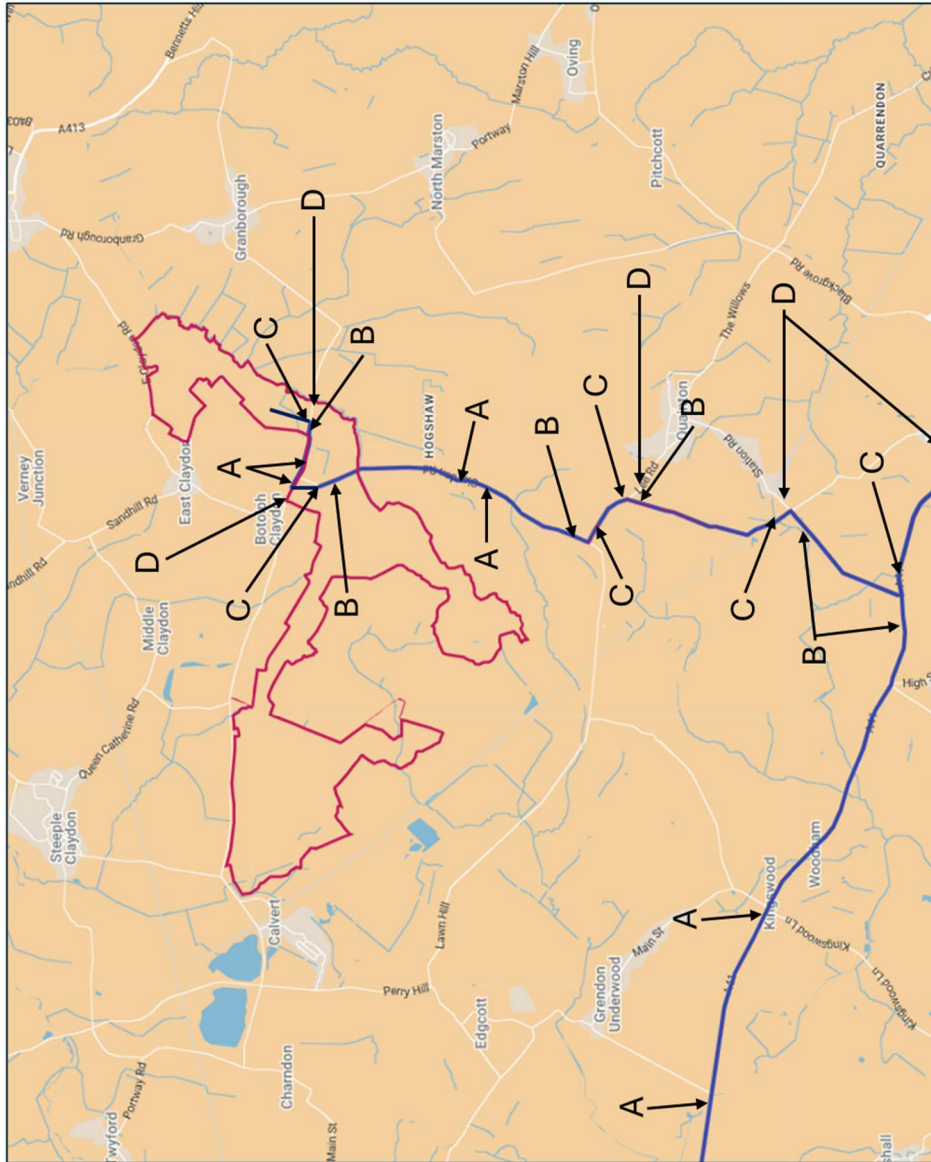

Indicative plate layout and plate type.
Exact details to be agreed with Buckinghamshire Council as part of the finalised CTMP.



Type A



Type B



Type C



Type D

[Annex 2: Road Improvement Plans and Access Junction Layouts](#)

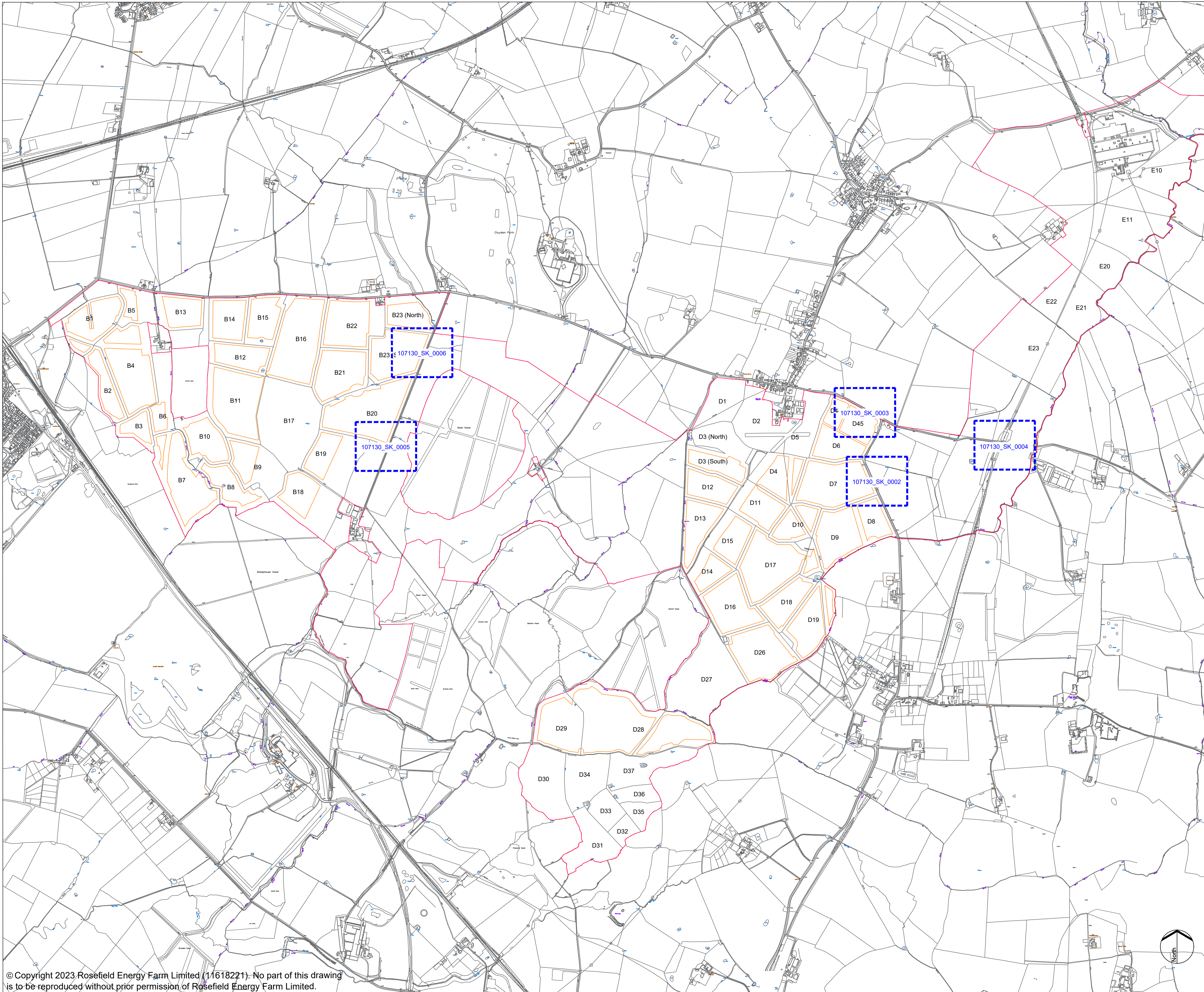

- NOTES:**
1. ALL DIMENSIONS ARE IN METERS UNLESS STATED OTHERWISE.
 2. ALL WORKS TO BE EXECUTED IN ACCORDANCE WITH THE DMRB, THE MANUAL OF CONTRACT DOCUMENTS FOR HIGHWAYS WORKS, DESIGN MANUAL FOR ROADS AND BRIDGES, AND TRAFFIC SIGNS MANUAL.
 3. ALL WORKS TO BE CARRIED OUT IN COMPLIANCE WITH THE REQUIREMENT OF THE STATUTORY AUTHORITIES AND CONSTRUCTION DESIGN MANAGEMENT REGULATIONS.
 4. ANY DISCREPANCIES TO BE REPORTED TO THE ENGINEER IMMEDIATELY SO THAT CLARIFICATION CAN BE SOUGHT PRIOR TO COMMENCEMENT OF WORKS.
 5. IT IS THE RESPONSIBILITY OF THE CONTRACTOR TO VERIFY ALL EXISTING SERVICES AND DRAINAGE CONNECTIONS PRIOR TO COMMENCING WORKS.

01	29/04/24	First Issue	SDM	SDM	GB
App	Date	Description	Drn	Chk	App

Rosefield Solar Farm



DOCUMENT:
 OUTLINE CONSTRUCTION TRAFFIC
 MANAGEMENT PLAN [EN010158/APP/7.5]

TITLE:
 APPLICATION DRAWINGS FOR APPROVAL
 REGULATION 5(2)(k)
 ACCESS JUNCTION LOCATION PLAN

PINS REFERENCE NUMBER:
 EN010158/APP/7.5

FIGURE SK001

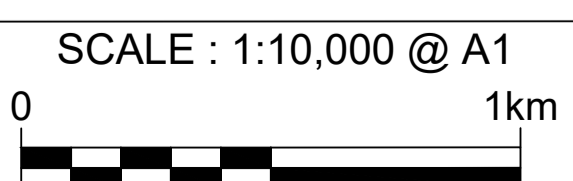

REV:
 P01



PROPOSED ACCESS JUNCTION GENERAL ARRANGEMENT
SCALE 1:200



PROPOSED ACCESS JUNCTION VISIBILITY SPLAY
SCALE 1:1000

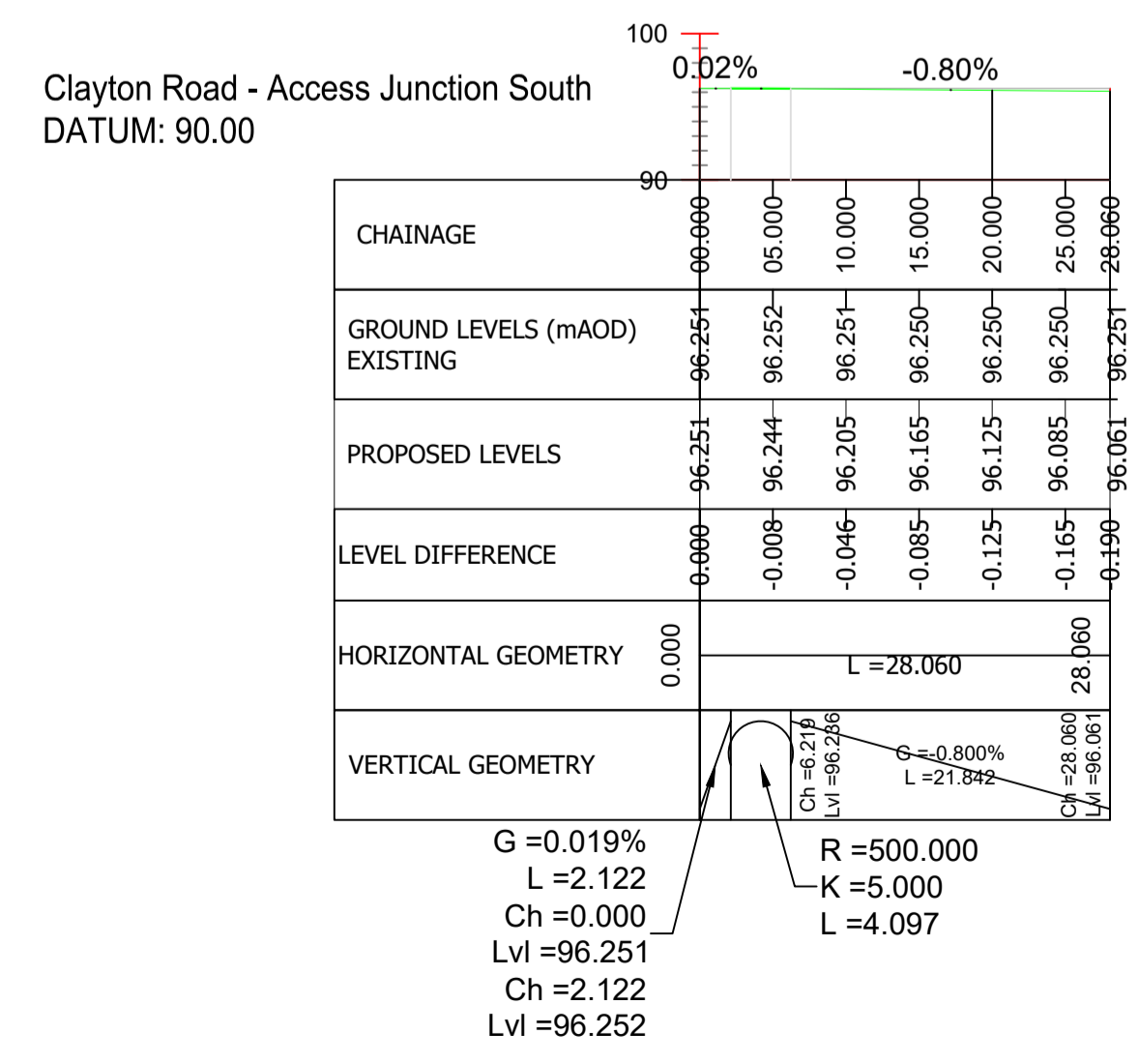

- NOTES:
1. ALL DIMENSIONS ARE IN METERS UNLESS STATED OTHERWISE.
 2. ALL WORKS TO BE EXECUTED IN ACCORDANCE WITH THE DMRB, THE MANUAL OF CONTRACT DOCUMENTS FOR HIGHWAYS WORKS, DESIGN MANUAL FOR ROADS AND BRIDGES, AND TRAFFIC SIGNS MANUAL.
 3. ALL WORKS TO BE CARRIED OUT IN COMPLIANCE WITH THE REQUIREMENT OF THE STATUTORY AUTHORITIES AND CONSTRUCTION DESIGN MANAGEMENT REGULATIONS.
 4. ANY DISCREPANCIES TO BE REPORTED TO THE ENGINEER IMMEDIATELY SO THAT CLARIFICATION CAN BE SOUGHT PRIOR TO COMMENCEMENT OF WORKS.
 5. IT IS THE RESPONSIBILITY OF THE CONTRACTOR TO VERIFY ALL EXISTING SERVICES AND DRAINAGE CONNECTIONS PRIOR TO COMMENCING WORKS.

LEGEND:

- PROPOSED ROAD CONSTRUCTION
- JUNCTION VISIBILITY 4.5m x 215m

App	Date	Description	Drn	Chk	App
02	18/02/26	Second Issue	JS	GB	GB
01	29/04/24	First Issue	SDM	SDM	GB

Rosefield Solar Farm

DOCUMENT:
OUTLINE CONSTRUCTION TRAFFIC MANAGEMENT PLAN [EN010158/APP/7.5]

TITLE:
APPLICATION DRAWINGS FOR APPROVAL REGULATION 5(2)(K)
PROPOSED SITE ACCESS JUNCTION
CLAYTON ROAD SOUTH

PINS REFERENCE NUMBER:
EN010158/APP/7.5.2

FIGURE SK002

SCALE : 1:AS SHOWN @ A1
0 1km

REV: P02

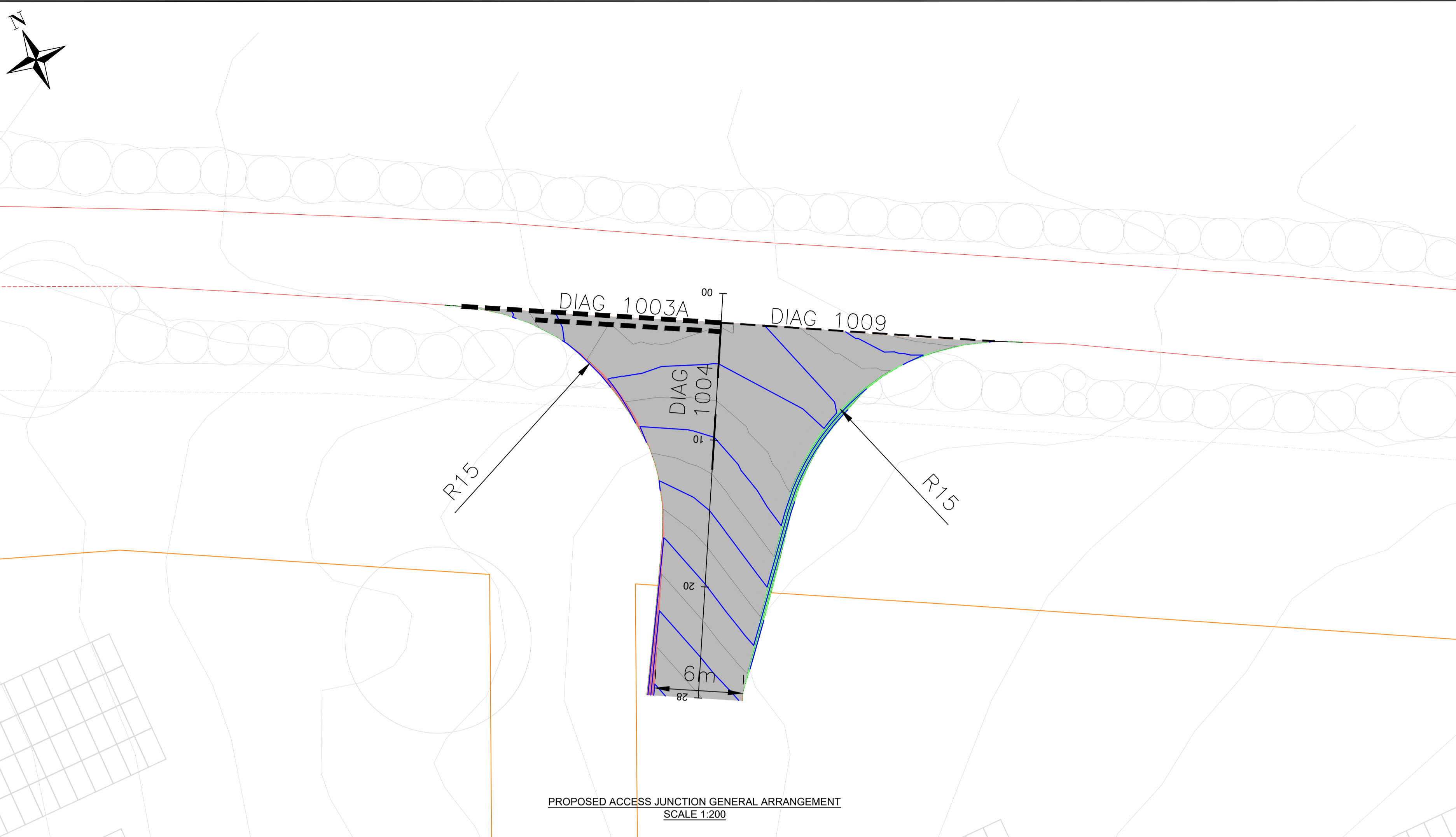

Clayton Road - Access Junction North
DATUM: 100.00

CHAINAGE	GROUND LEVELS (mAOD) EXISTING	PROPOSED LEVELS	LEVEL DIFFERENCE	HORIZONTAL GEOMETRY	VERTICAL GEOMETRY
0+000	100.896	100.896	0.000	0.000	CH = 1.096 V = 100.254
0+050	101.009	100.896	-0.104		
0+100	100.796	100.796	0.000		
0+150	100.644	100.696	0.052		
0+200	100.584	100.596	0.012		
0+250	100.562	100.496	-0.066		
0+275	100.578	100.445	-0.133	L = 27.565	G = -2.000% L = 25.599
0+300	100.578	100.445	-0.133		CH = 27.695 V = 100.445

- NOTES:**
- ALL DIMENSIONS ARE IN METERS UNLESS STATED OTHERWISE.
 - ALL WORKS TO BE EXECUTED IN ACCORDANCE WITH THE DMRB, THE MANUAL OF CONTRACT DOCUMENTS FOR HIGHWAYS WORKS, DESIGN MANUAL FOR ROADS AND BRIDGES, AND TRAFFIC SIGNS MANUAL.
 - ALL WORKS TO BE CARRIED OUT IN COMPLIANCE WITH THE REQUIREMENT OF THE STATUTORY AUTHORITIES AND CONSTRUCTION DESIGN MANAGEMENT REGULATIONS.
 - ANY DISCREPANCIES TO BE REPORTED TO THE ENGINEER IMMEDIATELY SO THAT CLARIFICATION CAN BE SOUGHT PRIOR TO COMMENCEMENT OF WORKS.
 - IT IS THE RESPONSIBILITY OF THE CONTRACTOR TO VERIFY ALL EXISTING SERVICES AND DRAINAGE CONNECTIONS PRIOR TO COMMENCING WORKS.

- LEGEND:**
- PROPOSED ROAD CONSTRUCTION
 - JUNCTION VISIBILITY 4.5m x 215m
 - JUNCTION VISIBILITY 4.5m x 105m

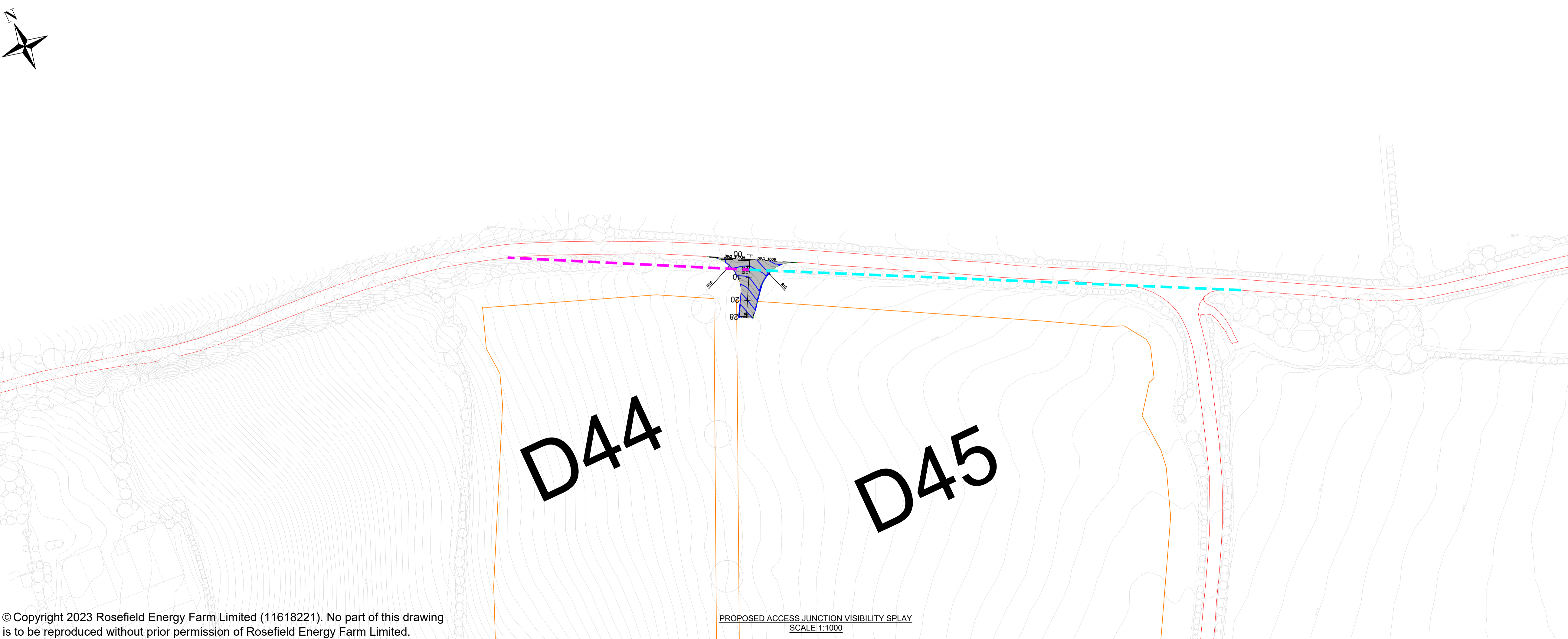

App	Date	Description	Drn	Chk	App
02	18/02/26	Second Issue	JS	GB	GB
01	29/04/24	First Issue	SDM	SDM	GB

Rosefield Solar Farm



DOCUMENT:
OUTLINE CONSTRUCTION TRAFFIC MANAGEMENT PLAN [EN010158/APP/7.5]

TITLE:
APPLICATION DRAWINGS FOR APPROVAL REGULATION 5(2)(K)
PROPOSED SITE ACCESS JUNCTION
CLAYTON ROAD NORTH

PINS REFERENCE NUMBER:
EN010158/APP/7.5.2

FIGURE SK003

SCALE : AS SHOWN @ A1



REV:
P02

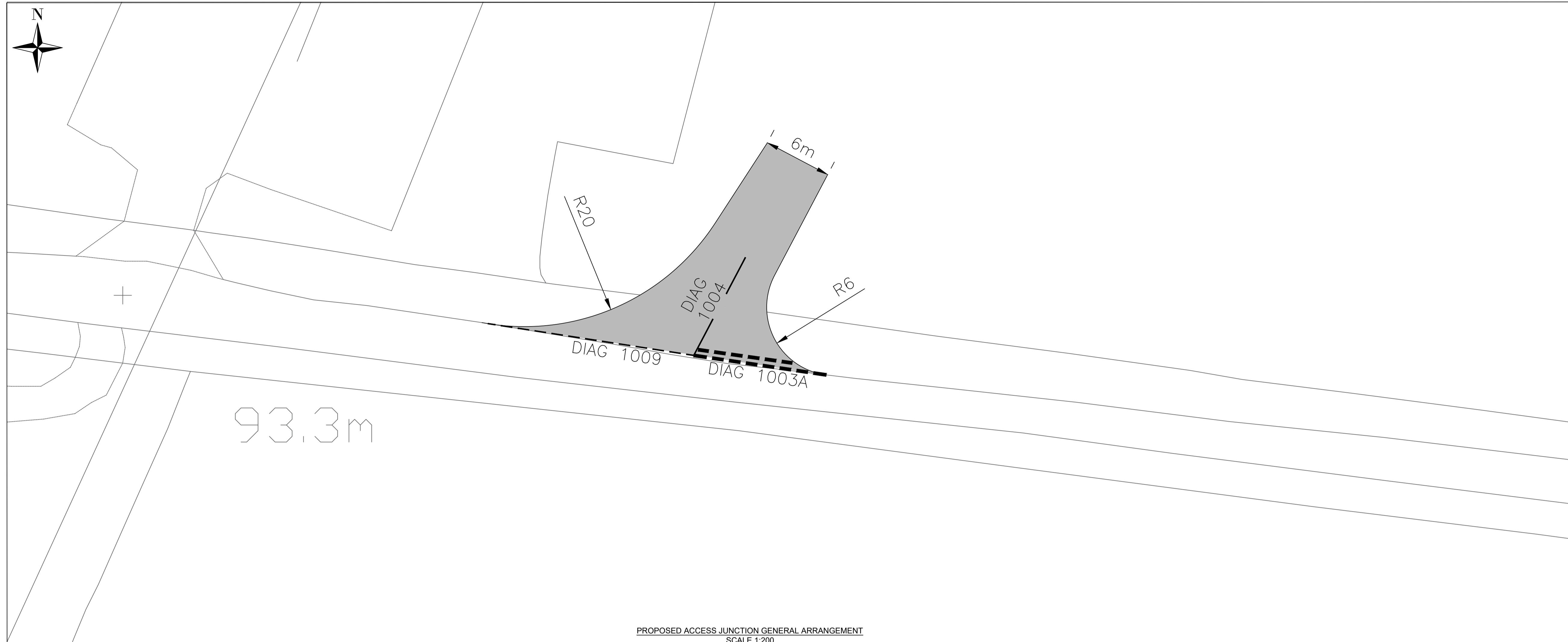

PROPOSED ACCESS JUNCTION GENERAL ARRANGEMENT
SCALE 1:200

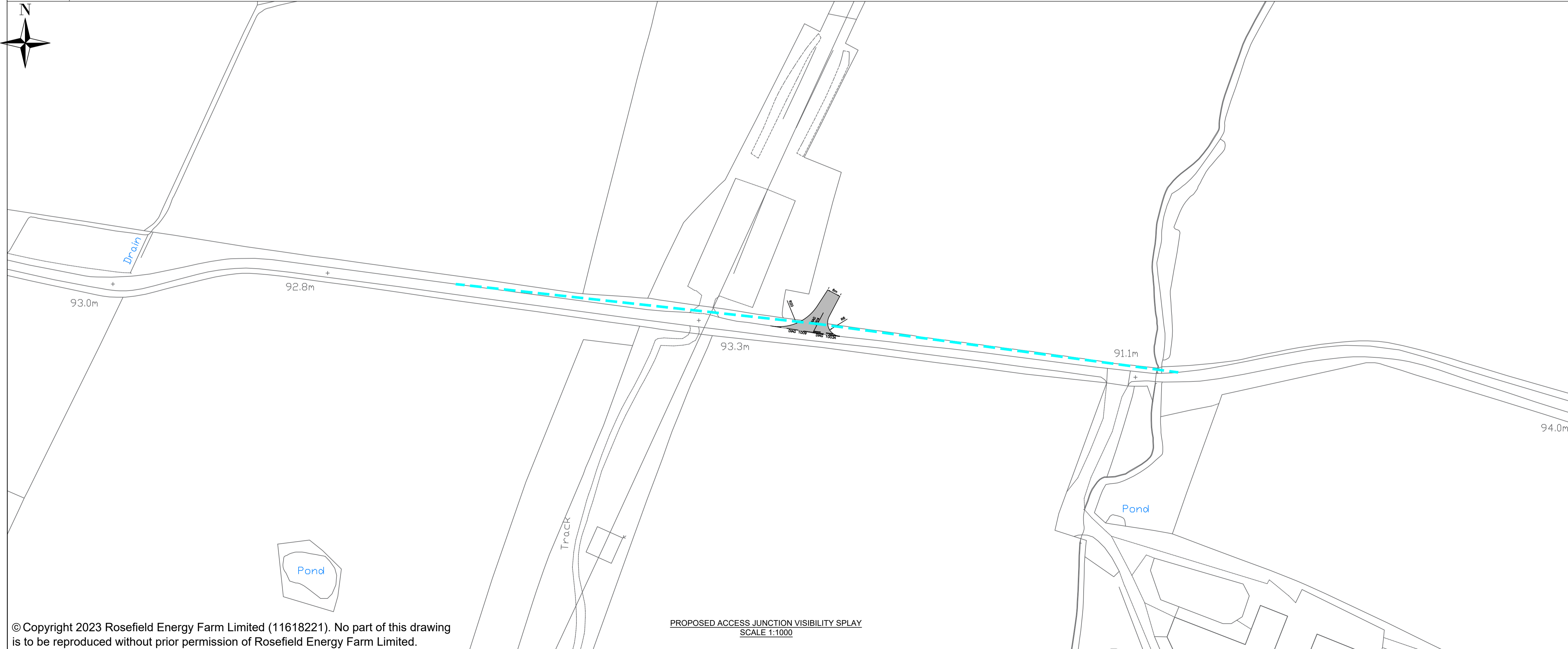

PROPOSED ACCESS JUNCTION VISIBILITY SPLAY
SCALE 1:1000

- NOTES:**
1. ALL DIMENSIONS ARE IN METERS UNLESS STATED OTHERWISE.
 2. ALL WORKS TO BE EXECUTED IN ACCORDANCE WITH THE DMRB, THE MANUAL OF CONTRACT DOCUMENTS FOR HIGHWAYS WORKS, DESIGN MANUAL FOR ROADS AND BRIDGES, AND TRAFFIC SIGNS MANUAL.
 3. ALL WORKS TO BE CARRIED OUT IN COMPLIANCE WITH THE REQUIREMENT OF THE STATUTORY AUTHORITIES AND CONSTRUCTION DESIGN MANAGEMENT REGULATIONS.
 4. ANY DISCREPANCIES TO BE REPORTED TO THE ENGINEER IMMEDIATELY SO THAT CLARIFICATION CAN BE SOUGHT PRIOR TO COMMENCEMENT OF WORKS.
 5. IT IS THE RESPONSIBILITY OF THE CONTRACTOR TO VERIFY ALL EXISTING SERVICES AND DRAINAGE CONNECTIONS PRIOR TO COMMENCING WORKS.

- LEGEND:**
- PROPOSED ROAD CONSTRUCTION
 - JUNCTION VISIBILITY 4.5m x 215m

02	18/02/26	Second Issue	JS	GB	GB
01	29/04/24	First Issue	SDM	SDM	GB
App	Date	Description	Drn	Chk	App

Rosefield Solar Farm

DOCUMENT:
OUTLINE CONSTRUCTION TRAFFIC
MANAGEMENT PLAN [EN010158/APP/7.5]

TITLE:
APPLICATION DRAWINGS FOR APPROVAL REGULATION 5(2)(K)
SUBSTATION
PROPOSED SITE ACCESS JUNCTION

PINS REFERENCE NUMBER:
EN010158/APP/7.5.2

FIGURE SK004

SCALE : AS SHOWN @ A1

REV: P02

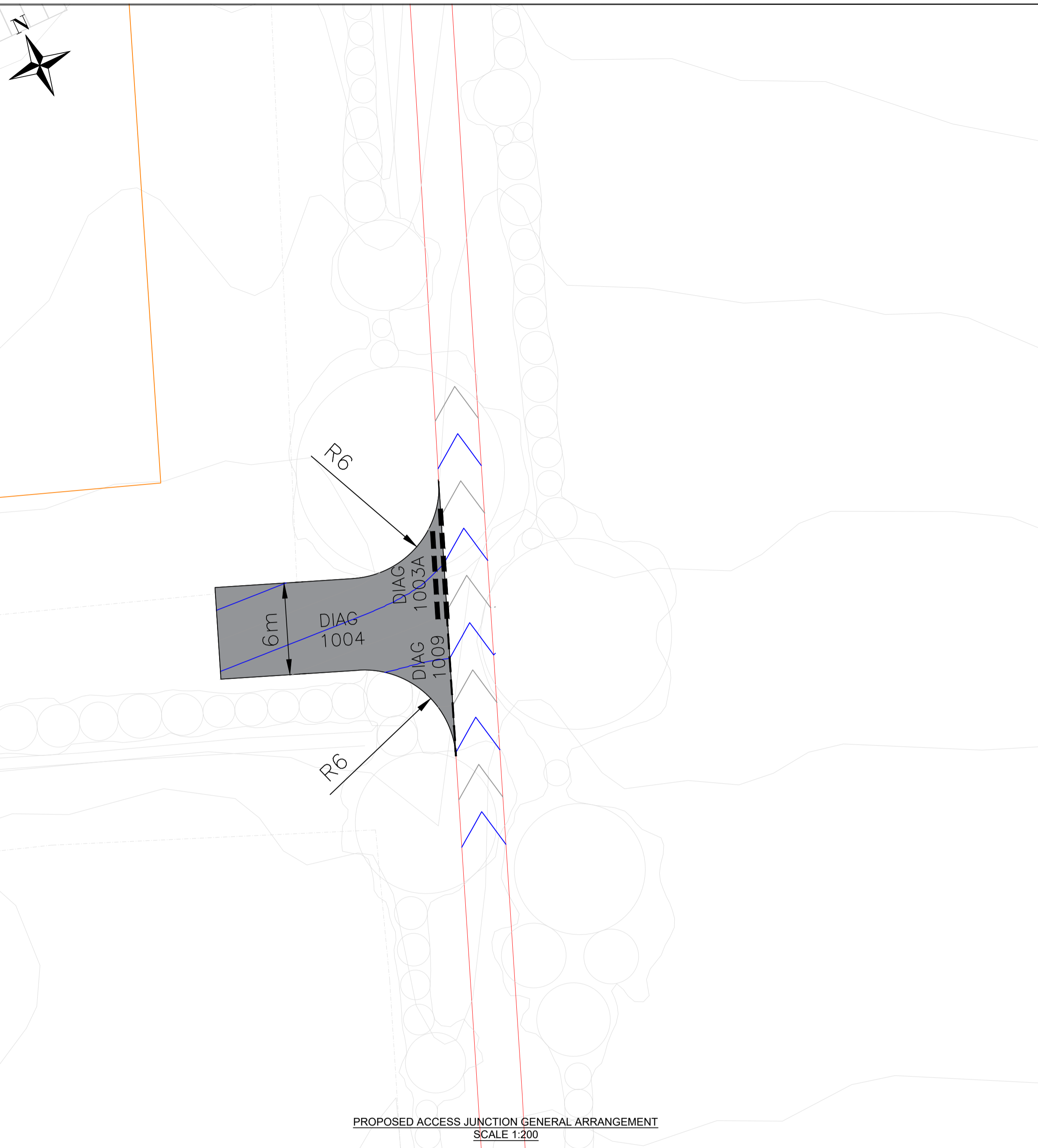

PROPOSED ACCESS JUNCTION GENERAL ARRANGEMENT
SCALE 1:200

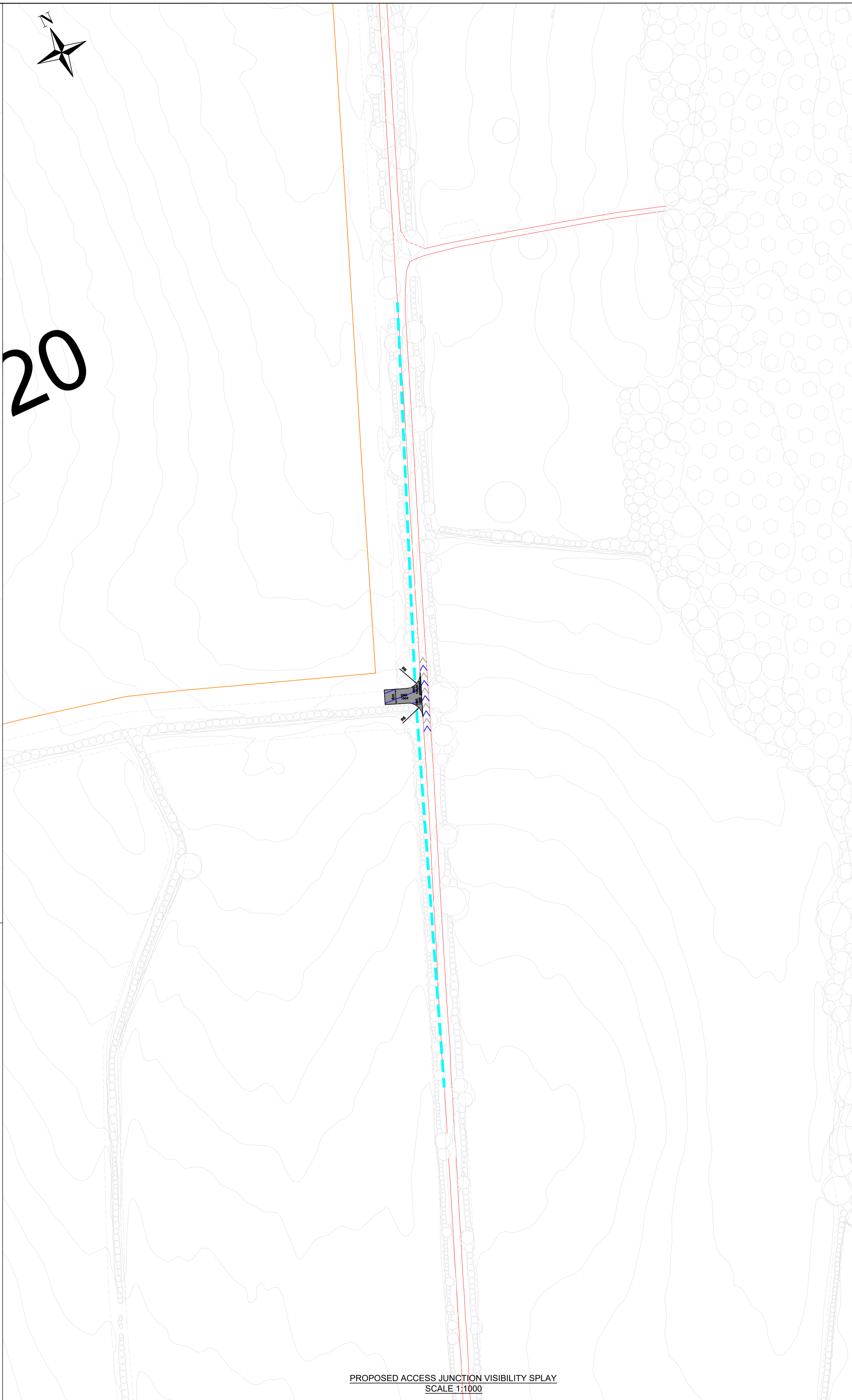

PROPOSED ACCESS JUNCTION VISIBILITY SPLAY
SCALE 1:1000

NOTES:

1. ALL DIMENSIONS ARE IN METERS UNLESS STATED OTHERWISE.
2. ALL WORKS TO BE EXECUTED IN ACCORDANCE WITH THE DMRB, THE MANUAL OF CONTRACT DOCUMENTS FOR HIGHWAYS WORKS, DESIGN MANUAL FOR ROADS AND BRIDGES, AND TRAFFIC SIGNS MANUAL.
3. ALL WORKS TO BE CARRIED OUT IN COMPLIANCE WITH THE REQUIREMENT OF THE STATUTORY AUTHORITIES AND CONSTRUCTION DESIGN MANAGEMENT REGULATIONS.
4. ANY DISCREPANCIES TO BE REPORTED TO THE ENGINEER IMMEDIATELY SO THAT CLARIFICATION CAN BE SOUGHT PRIOR TO COMMENCEMENT OF WORKS.
5. IT IS THE RESPONSIBILITY OF THE CONTRACTOR TO VERIFY ALL EXISTING SERVICES AND DRAINAGE CONNECTIONS PRIOR TO COMMENCING WORKS.

LEGEND:

- PROPOSED ROAD CONSTRUCTION
- JUNCTION VISIBILITY 2.4m x 160m

20

02	03/2026	Second Issue	SDM	SDM	GB
01	29/04/24	First Issue	SDM	SDM	GB
App	Date	Description	Drm	Chk	App

Rosefield Solar Farm



DOCUMENT:
OUTLINE CONSTRUCTION TRAFFIC
MANAGEMENT PLAN [EN010158/APP/7.5]

TITLE:
APPLICATION DRAWINGS FOR APPROVAL REGULATION 5(2)(K)
THREE POINT LANE
PROPOSED JUNCTIONS - SOUTH

PINS REFERENCE NUMBER:
EN010158/APP/7.5

FIGURE SK005

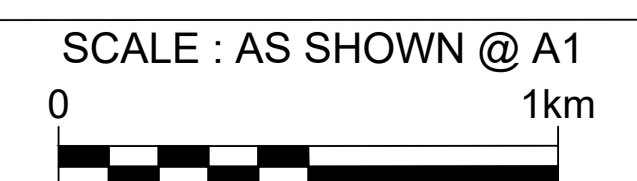

REV:
P01

CHAINAGE	THREE POINT LANE EAST		THREE POINT LANE WEST	
	0.000	10.000	0.000	10.000
EXISTING GROUND LEVEL	91.516	91.509	91.516	91.311
ALIGNMENT LEVEL	91.459	91.527	91.458	91.389
VERTICAL ALIGNMENT	G= 0.800% 1: 125.0		G= -0.800% 1: -125.0	
HORIZONTAL ALIGNMENT				

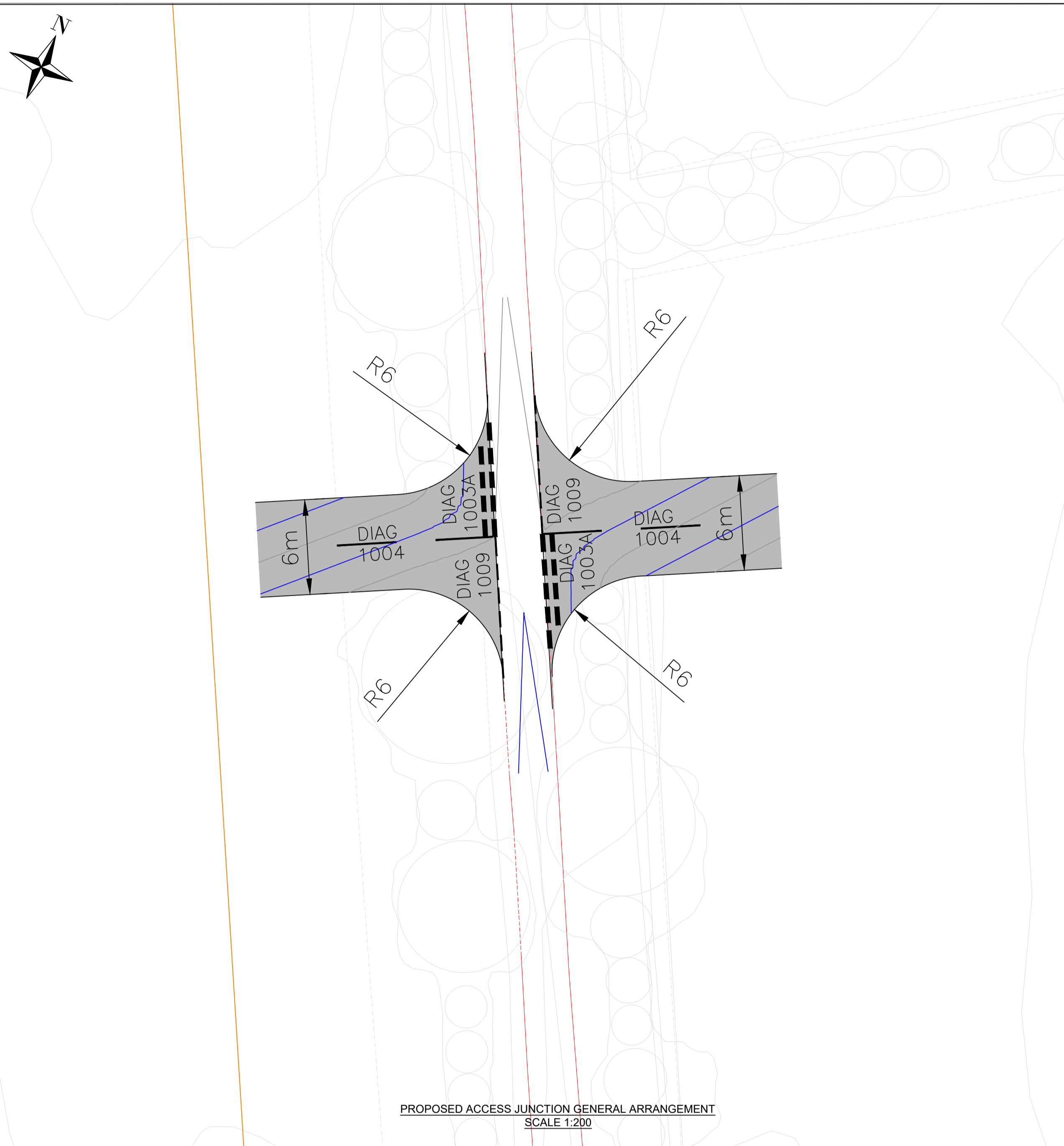

- NOTES:**
1. ALL DIMENSIONS ARE IN METERS UNLESS STATED OTHERWISE.
 2. ALL WORKS TO BE EXECUTED IN ACCORDANCE WITH THE DMRB, THE MANUAL OF CONTRACT DOCUMENTS FOR HIGHWAYS WORKS, DESIGN MANUAL FOR ROADS AND BRIDGES, AND TRAFFIC SIGNS MANUAL.
 3. ALL WORKS TO BE CARRIED OUT IN COMPLIANCE WITH THE REQUIREMENT OF THE STATUTORY AUTHORITIES AND CONSTRUCTION DESIGN MANAGEMENT REGULATIONS.
 4. ANY DISCREPANCIES TO BE REPORTED TO THE ENGINEER IMMEDIATELY SO THAT CLARIFICATION CAN BE SOUGHT PRIOR TO COMMENCEMENT OF WORKS.
 5. IT IS THE RESPONSIBILITY OF THE CONTRACTOR TO VERIFY ALL EXISTING SERVICES AND DRAINAGE CONNECTIONS PRIOR TO COMMENCING WORKS.

LEGEND:

- PROPOSED ROAD CONSTRUCTION
- JUNCTION VISIBILITY 2.4m x 160m

THREE POINT LANE

CHAINAGE	0.000	1.454	10.000	16.464
EXISTING GROUND LEVEL	88.185		88.260	88.323
ALIGNMENT LEVEL	88.152		88.250	88.329
VERTICAL ALIGNMENT	G= 1.140% 1: 87.7			
HORIZONTAL ALIGNMENT				

TPL NORTH - ACCESS JUNCTION EAST
SCALE 1:500

THREE POINT LANE

CHAINAGE	0.000	1.540	10.000	16.540
EXISTING GROUND LEVEL	88.185		88.127	88.100
ALIGNMENT LEVEL	88.150		88.083	88.030
VERTICAL ALIGNMENT	G= -0.800% 1: -125.0			
HORIZONTAL ALIGNMENT				

TPL NORTH - ACCESS JUNCTION WEST
SCALE 1:500

01	29/04/24	First Issue	SDM	SDM	GB
App	Date	Description	Drn	Chk	App

Rosefield Solar Farm

DOCUMENT:
OUTLINE CONSTRUCTION TRAFFIC
MANAGEMENT PLAN [EN10158/APP/7.5]

TITLE:
APPLICATION DRAWINGS FOR APPROVAL REGULATION 5(2)(K)
THREE POINT LANE
PROPOSED JUNCTIONS - NORTH

PINS REFERENCE NUMBER:
EN10158/APP/7.5

FIGURE SK006

SCALE : AS SHOWN @ A1
0 1km

REV: P01



CLAYTON ROAD SOUTH ENTRY

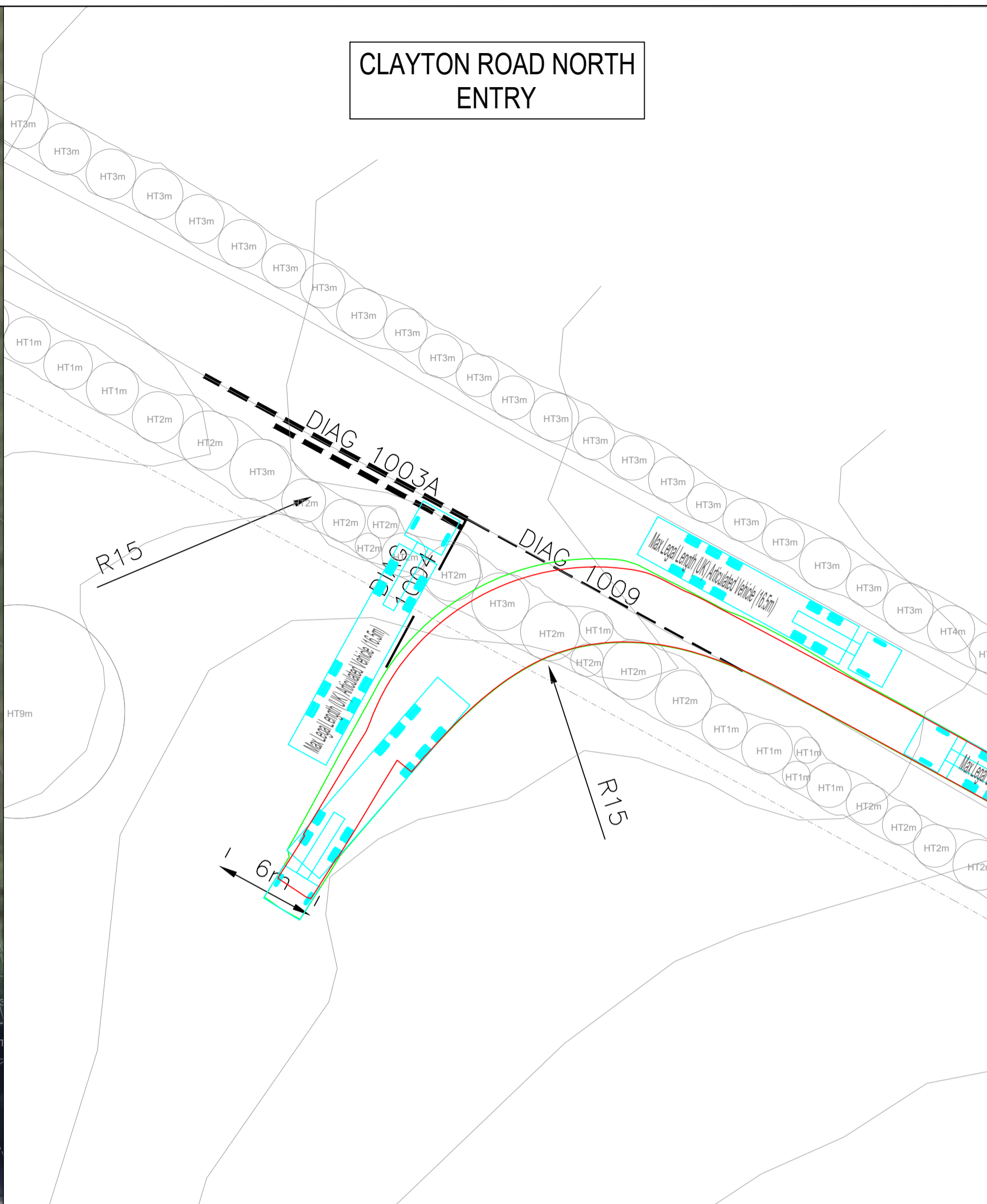

CLAYTON ROAD NORTH ENTRY

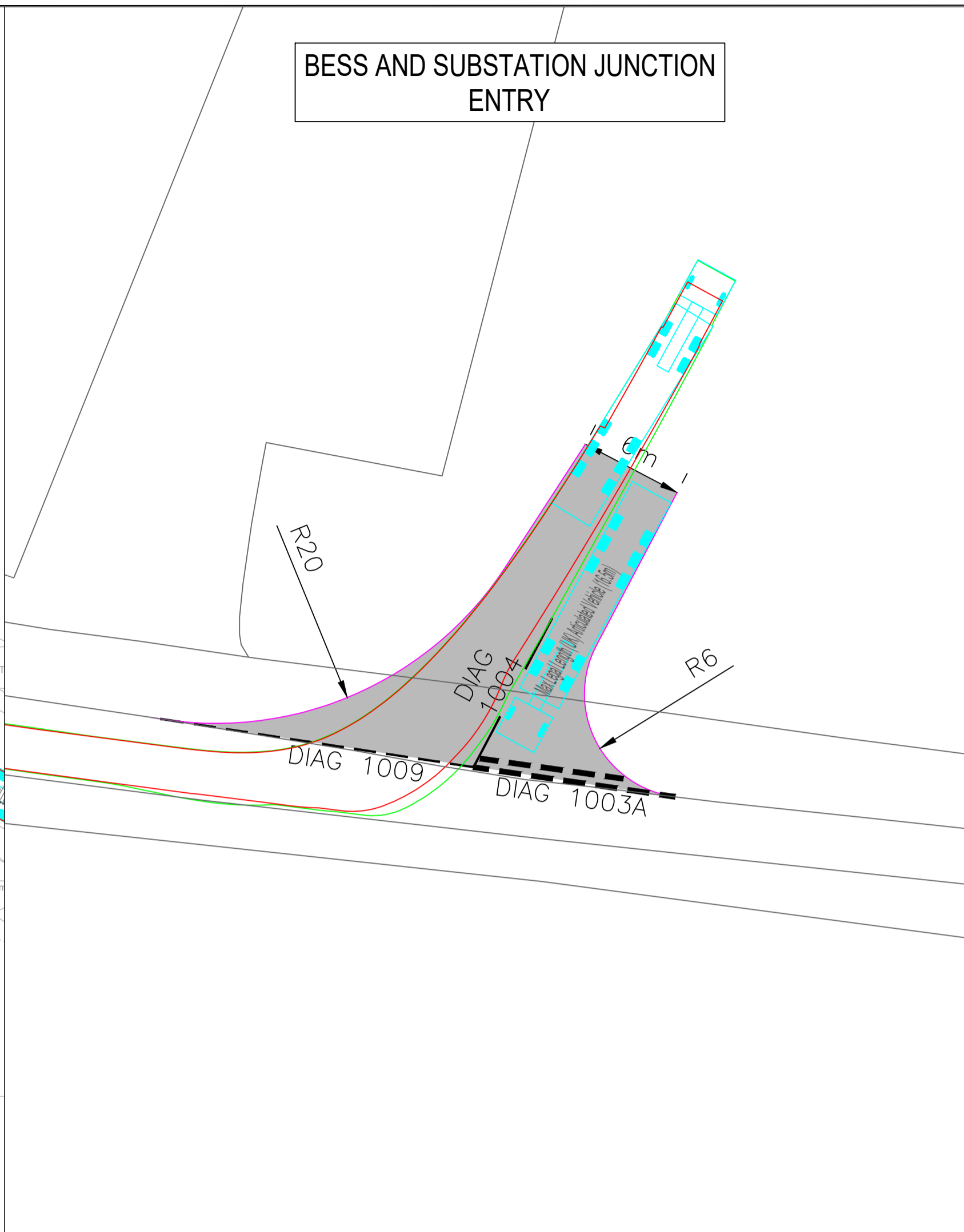

BESS AND SUBSTATION JUNCTION ENTRY



CLAYTON ROAD SOUTH EXIT

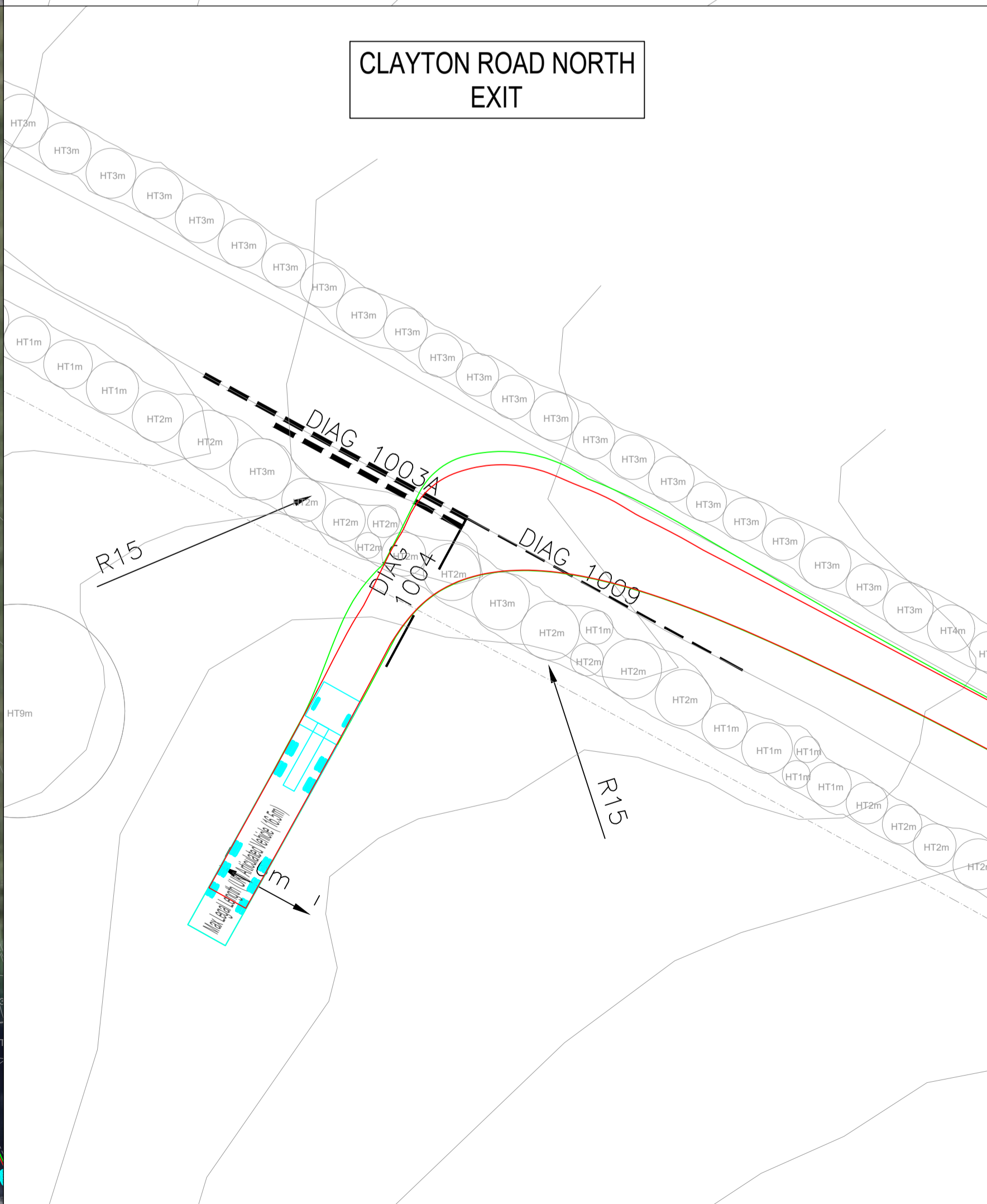

CLAYTON ROAD NORTH EXIT

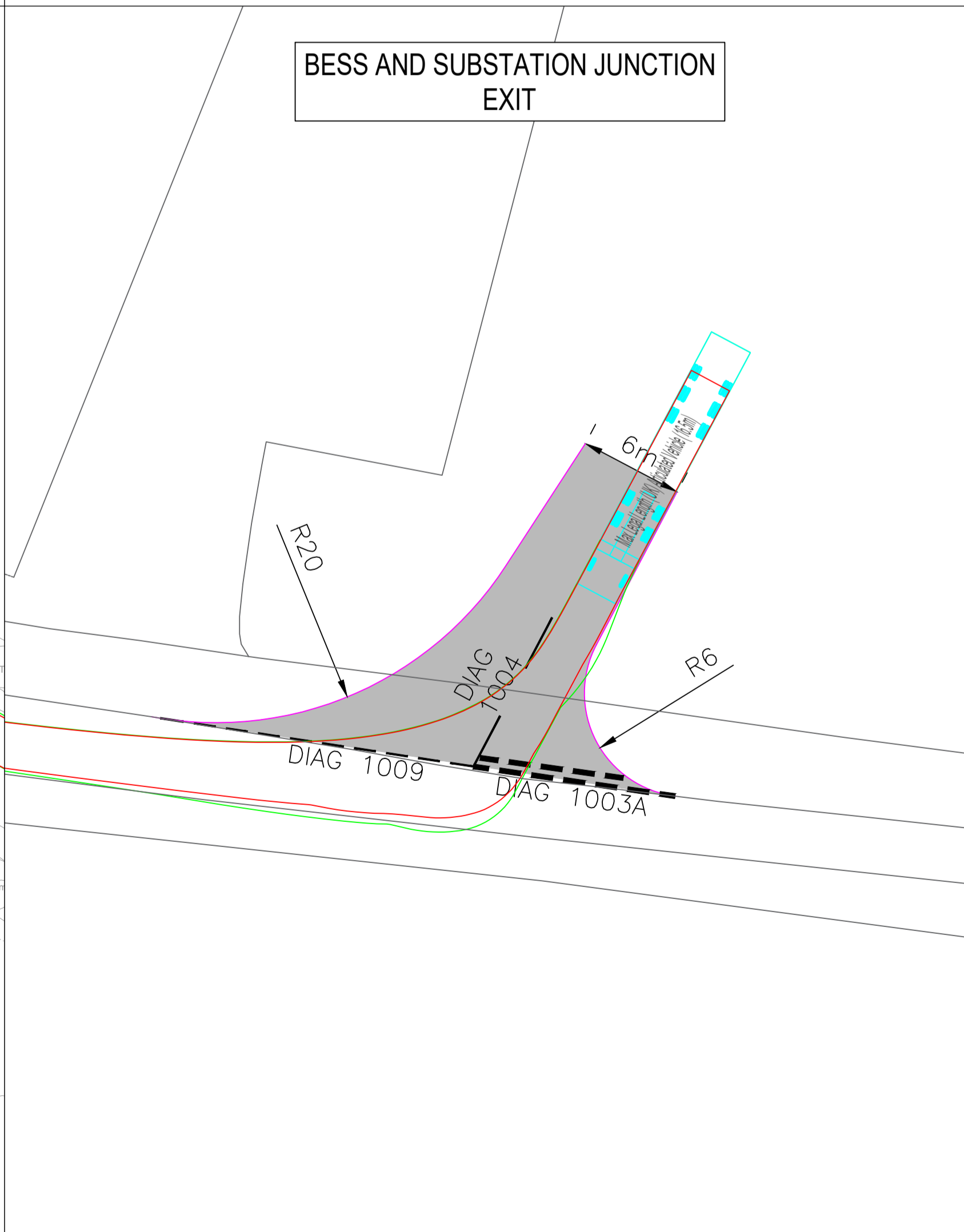

BESS AND SUBSTATION JUNCTION EXIT

- NOTES:**
1. ALL DIMENSIONS ARE IN METERS UNLESS STATED OTHERWISE.
 2. ALL WORKS TO BE EXECUTED IN ACCORDANCE WITH THE DMRB, THE MANUAL OF CONTRACT DOCUMENTS FOR HIGHWAYS WORKS, DESIGN MANUAL FOR ROADS AND BRIDGES, AND TRAFFIC SIGNS MANUAL.
 3. ALL WORKS TO BE CARRIED OUT IN COMPLIANCE WITH THE REQUIREMENT OF THE STATUTORY AUTHORITIES AND CONSTRUCTION DESIGN MANAGEMENT REGULATIONS.
 4. ANY DISCREPANCIES TO BE REPORTED TO THE ENGINEER IMMEDIATELY SO THAT CLARIFICATION CAN BE SOUGHT PRIOR TO COMMENCEMENT OF WORKS.
 5. IT IS THE RESPONSIBILITY OF THE CONTRACTOR TO VERIFY ALL EXISTING SERVICES AND DRAINAGE CONNECTIONS PRIOR TO COMMENCING WORKS.

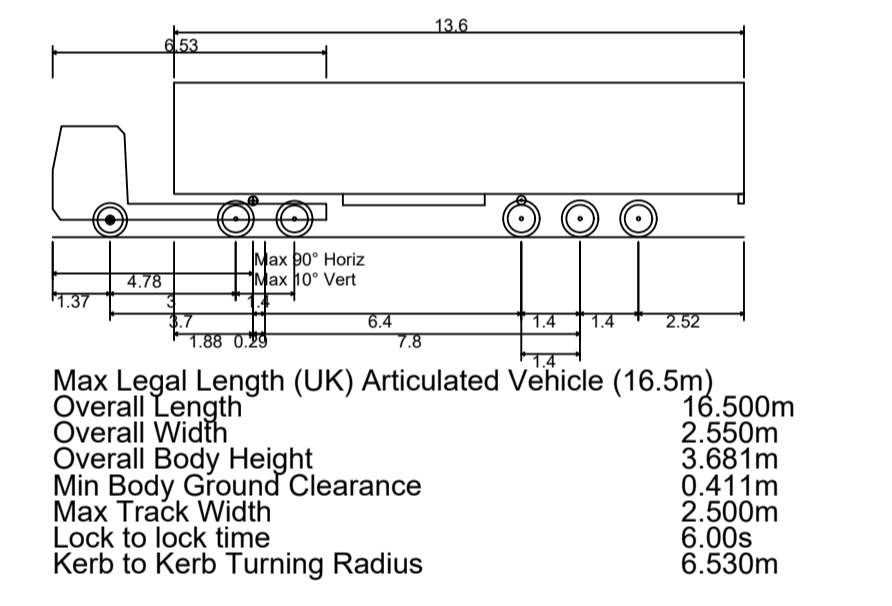
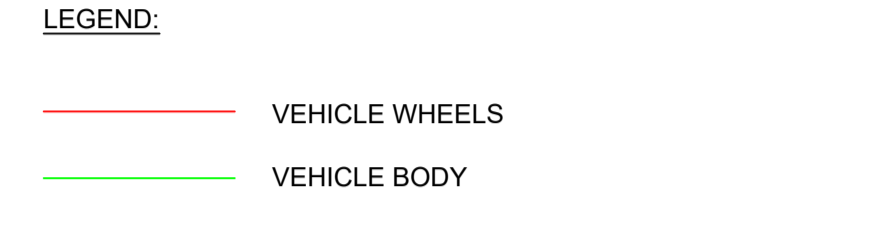

01	17/02/26	First Issue	JS	GB	GB
App	Date	Description	Drm	Chk	App

Rosefield Solar Farm

DOCUMENT:
 PROPOSED JUNCTIONS
 SWEEP PATH ANALYSIS

TITLE:
 APPLICATION DRAWINGS FOR APPROVAL REGULATION 5(2)(K)
 THREE POINT LANE
 PROPOSED JUNCTIONS - NORTH

PINS REFERENCE NUMBER:
 EN010158/APP/7.5

FIGURE SK007

SCALE : 1:250 @ A1

REV: P01

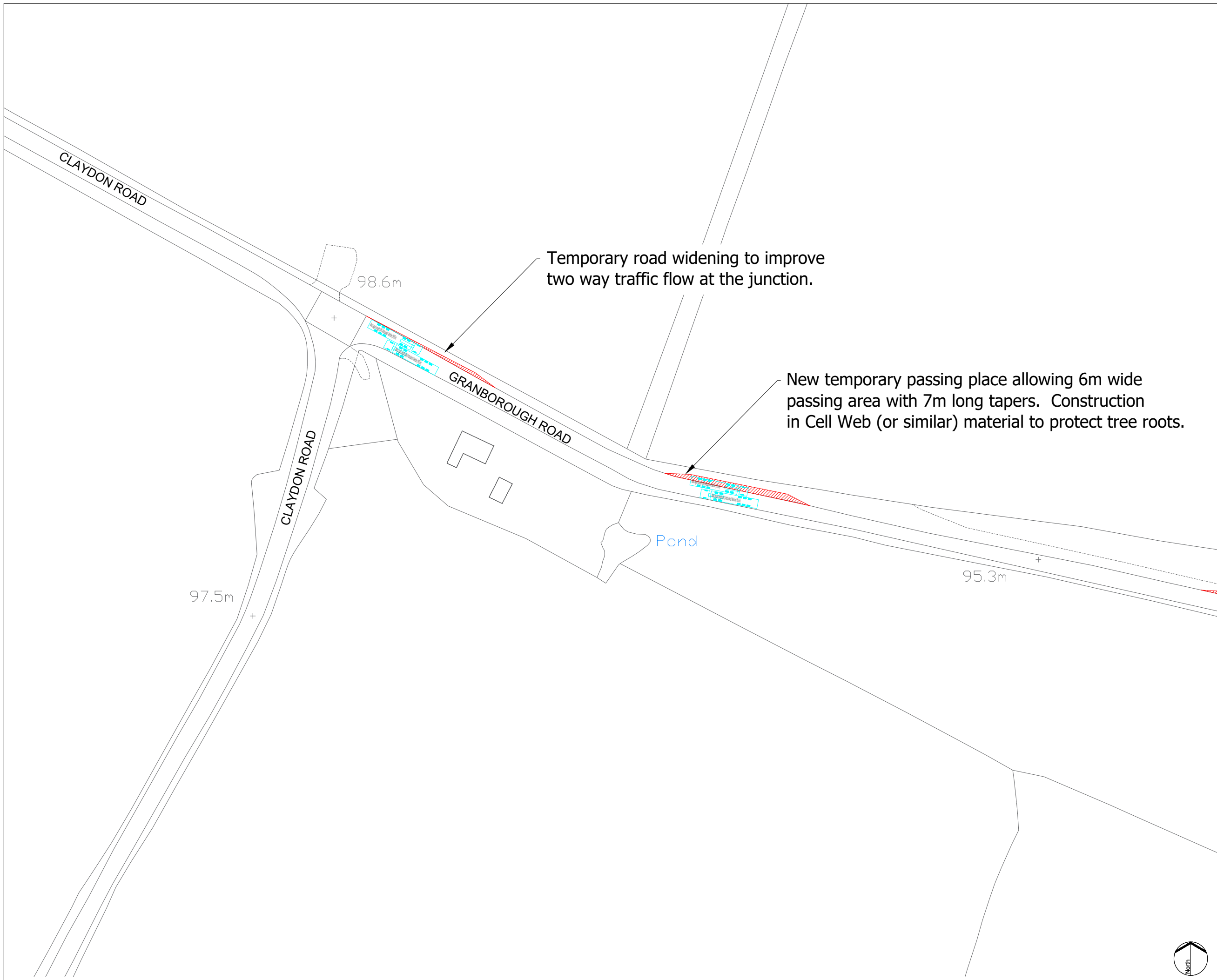

KEY:

	FTA MAXIMUM LEGAL ARTICULATED HGV
	PROPOSED LOAD BEARING SURFACE
	DCO LIMIT

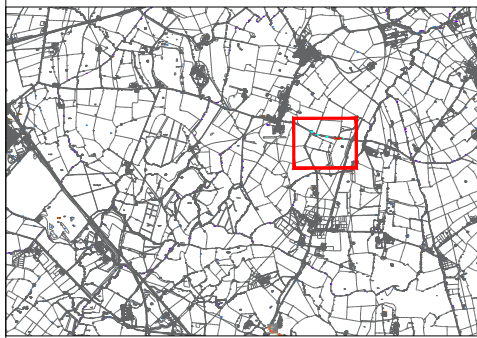

NOTES:
1. ALL DIMENSIONS ARE IN METRES UNLESS STATED OTHERWISE.

01	15/08/2025	FIRST ISSUE	AS	GB	GB
App	Date	Description	Drn	Chk	App

Rosefield Solar Farm



DOCUMENT:
OUTLINE CONSTRUCTION TRAFFIC MANAGEMENT PLAN [EN010158/APP/7.5]

TITLE:APPLICATION DRAWINGS FOR APPROVAL REGULATION 5(2)(k)
GRANBOROUGH ROAD MODIFICATIONS 01

PINS REFERENCE NUMBER:
EN010158/APP/7.5

FIGURE SK007
SCALE : 1:1000 @ A3





REV:
P01



New temporary passing place allowing 6m wide passing area with 7m long tapers. Construction in Cell Web (or similar) material to protect tree roots.

New temporary road widening at the bend allowing 6m wide passing area with 7m long tapers. Construction in Cell Web (or similar) material to protect tree roots.

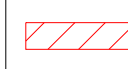
KEY:

-  FTA MAXIMUM LEGAL ARTICULATED HGV
-  PROPOSED LOAD BEARING SURFACE
-  DCO LIMIT

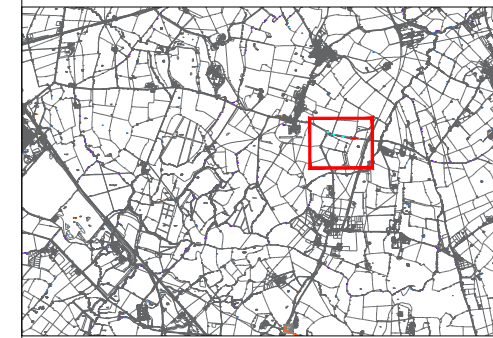

NOTES:
1. ALL DIMENSIONS ARE IN METRES UNLESS STATED OTHERWISE.

01	15/08/2025	FIRST ISSUE	AS	GB	GB
App	Date	Description	Drn	Chk	App

Rosefield Solar Farm



DOCUMENT:
OUTLINE CONSTRUCTION TRAFFIC MANAGEMENT PLAN [EN010158/APP/7.5]



TITLE: APPLICATION DRAWINGS FOR APPROVAL
REGULATION 5(2)(k)
GRANBOROUGH ROAD MODIFICATIONS 02

PINS REFERENCE NUMBER:
EN010158/APP/7.5

FIGURE SK008
SCALE : 1:1000 @ A3

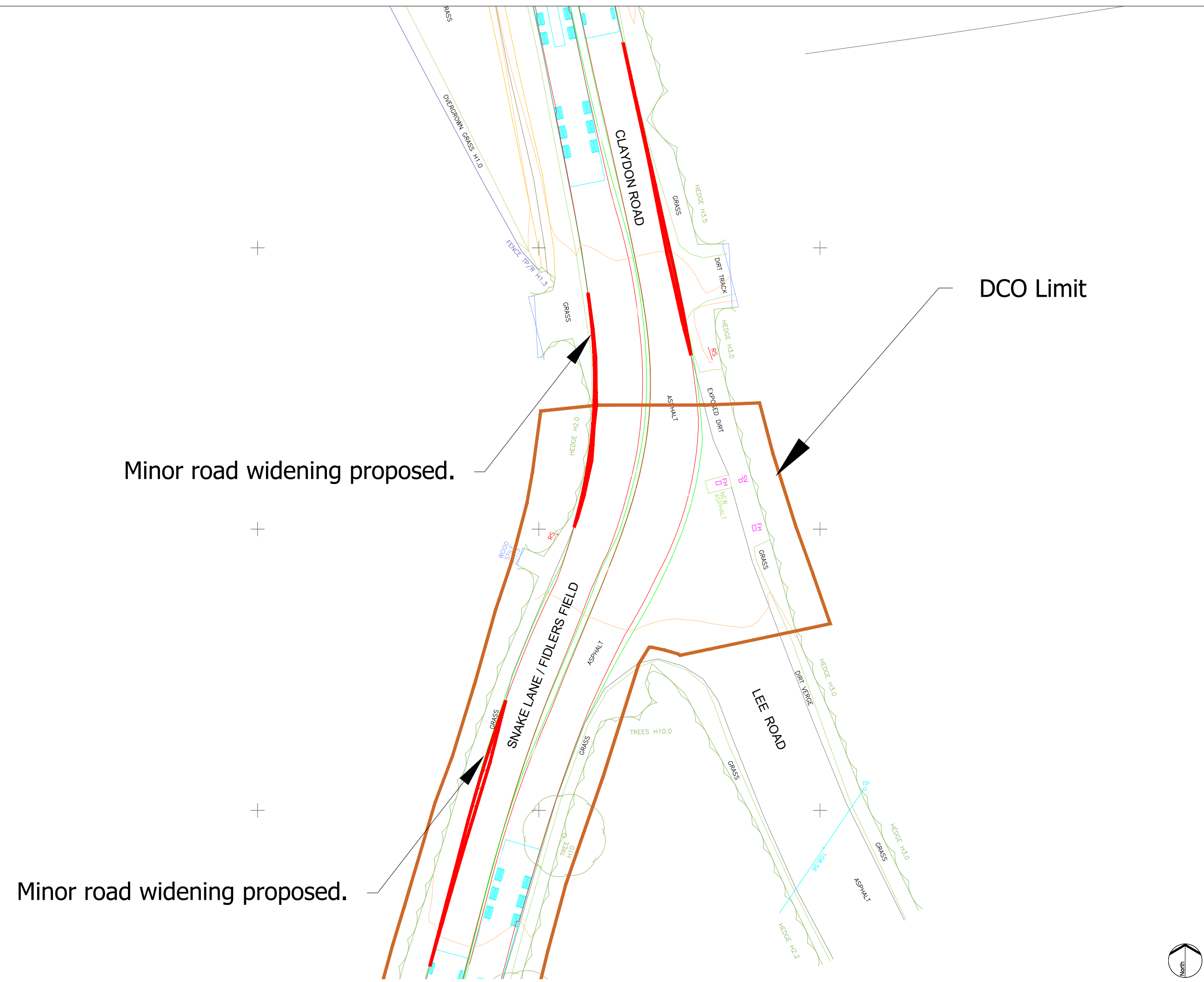
REV:
P01

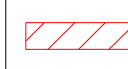

- KEY:
-  FTA MAXIMUM LEGAL ARTICULATED HGV
 -  PROPOSED LOAD BEARING SURFACE
 -  DCO LIMIT

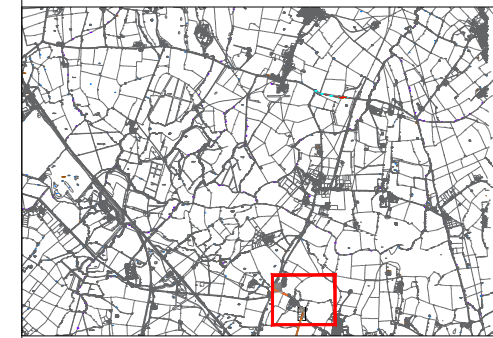

NOTES:
1. ALL DIMENSIONS ARE IN METRES UNLESS STATED OTHERWISE.

Minor road widening proposed.

DCO Limit

Minor road widening proposed.

01	15/08/2025	FIRST ISSUE	AS	GB	GB
App	Date	Description	Drm	Chk	App

Rosefield Solar Farm



DOCUMENT:
OUTLINE CONSTRUCTION TRAFFIC MANAGEMENT PLAN [EN010158/APP/7.5]

TITLE: APPLICATION DRAWINGS FOR APPROVAL REGULATION 5(2)(k)
SNAKE LANE / FIDLERS FIELD MODIFICATIONS

PINS REFERENCE NUMBER:
EN010158/APP/7.5

FIGURE SK009
SCALE : 1:250 @ A3



REV:
P01

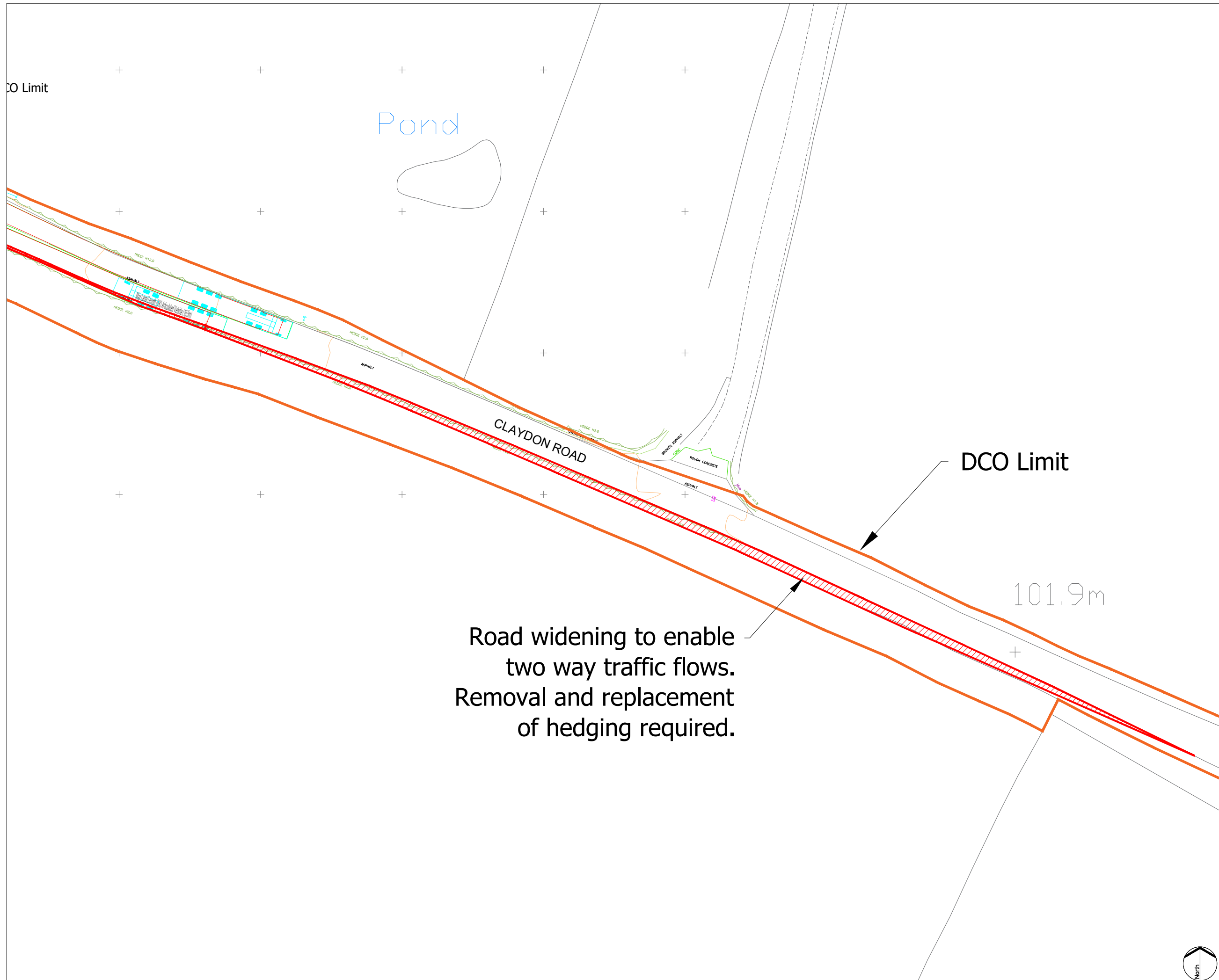

- KEY:
- FTA MAXIMUM LEGAL ARTICULATED HGV
 - PROPOSED LOAD BEARING SURFACE
 - DCO LIMIT

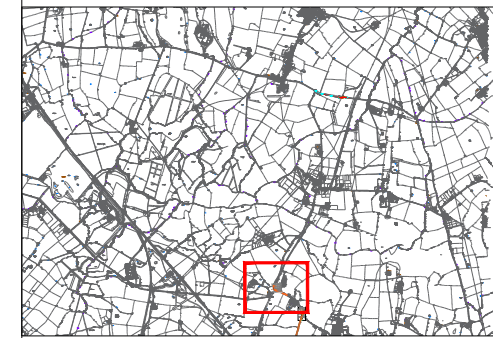

NOTES:
1. ALL DIMENSIONS ARE IN METRES UNLESS STATED OTHERWISE.

01	15/08/2025	FIRST ISSUE	AS	GB	GB
App	Date	Description	Drn	Chk	App

Rosefield Solar Farm



DOCUMENT:
OUTLINE CONSTRUCTION TRAFFIC MANAGEMENT PLAN [EN010158/APP/7.5]

TITLE: APPLICATION DRAWINGS FOR APPROVAL REGULATION 5(2)(k)
CLAYDON ROAD WIDENING MODIFICATIONS

PINS REFERENCE NUMBER:
EN010158/APP/7.5

FIGURE SK010

SCALE : 1:500 @ A3

REV:
P01



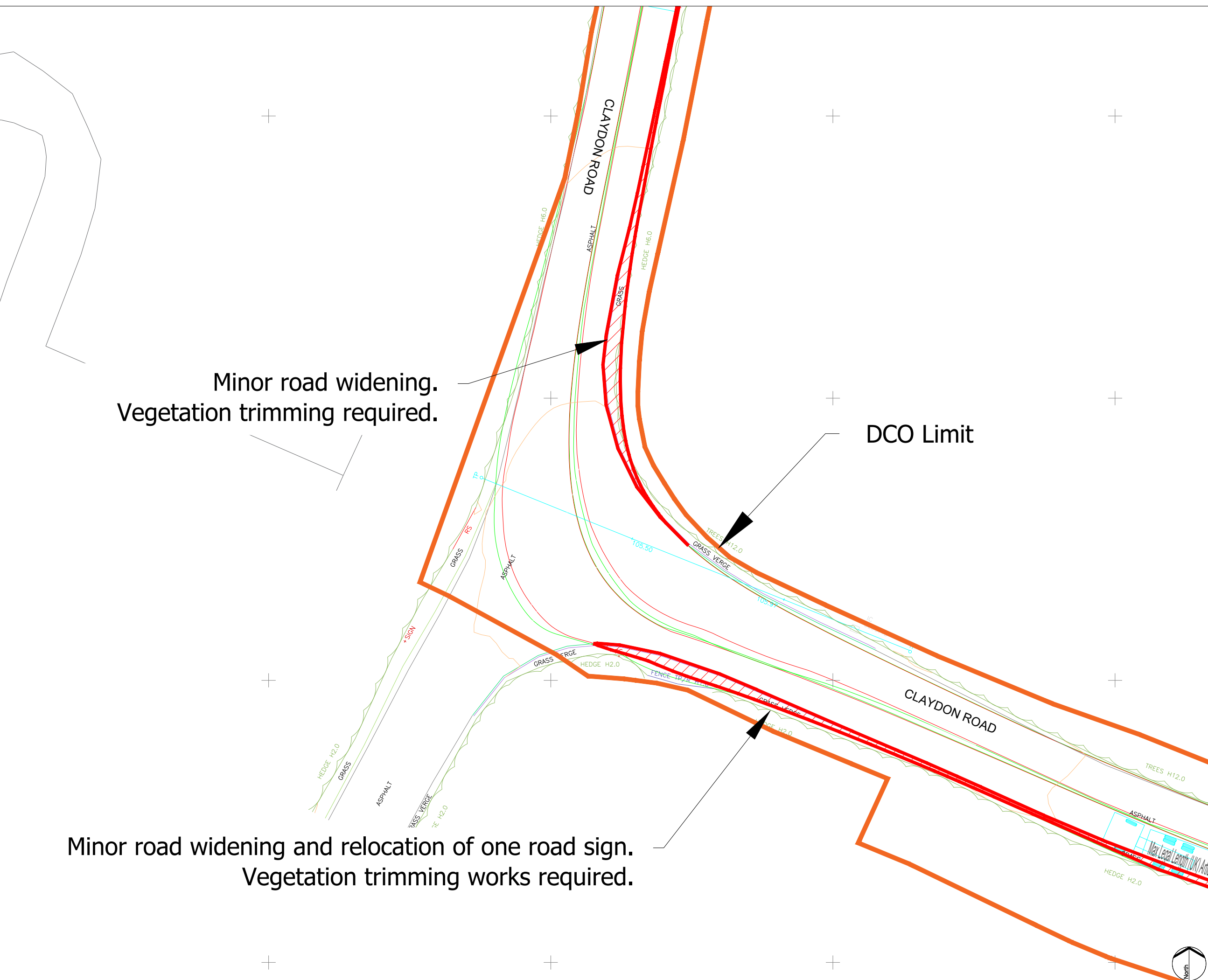

KEY:

	FTA MAXIMUM LEGAL ARTICULATED HGV
	PROPOSED LOAD BEARING SURFACE
	DCO LIMIT

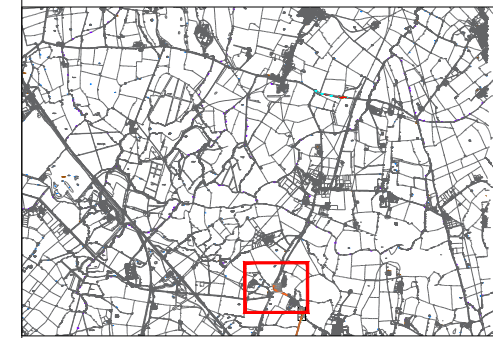

NOTES:
1. ALL DIMENSIONS ARE IN METRES UNLESS STATED OTHERWISE.

01	15/08/2025	FIRST ISSUE	AS	GB	GB
App	Date	Description	Drn	Chk	App

Rosefield Solar Farm



DOCUMENT:
OUTLINE CONSTRUCTION TRAFFIC MANAGEMENT PLAN [EN010158/APP/7.5]

TITLE: APPLICATION DRAWINGS FOR APPROVAL REGULATION 5(2)(k)
CLAYDON ROAD JUNCTION MODIFICATIONS NEAR SHIPTON LEE

PINS REFERENCE NUMBER:
EN010158/APP/7.5

FIGURE SK011
SCALE : 1:250 @ A3

REV:
P01

8.1. References

- **Ref. 1** Department for Energy Security and Net Zero. (2023). Overarching National Policy Statement for Energy (EN-1). Available online: <https://www.gov.uk/government/publications/overarching-national-policy-statement-for-energy-en-1>
- **Ref. 2:** Department for Energy Security and Net Zero (2023). National Policy Statement for Renewable Energy Infrastructure (EN-3). Available online: <https://www.gov.uk/government/publications/national-policy-statement-for-renewable-energy-infrastructure-en-3>
- **Ref. 3:** Department for Energy Security and Net Zero (2023). National Policy Statement for Electricity Networks Infrastructure (EN-5). Available online: <https://www.gov.uk/government/publications/national-policy-statement-for-electricity-networks-infrastructure-en-5>
- **Ref. 4:** Ministry of Housing, Communities and Local Government and Department for Levelling Up, Housing and Communities (2023) National Planning Policy Framework. Available online: <https://www.gov.uk/government/publications/national-planning-policy-framework--2>
- **Ref. 5:** Vale of Aylesbury Local Plan (VALP) 2013 – 2033 Adopted Plan (2021). Available online: https://buckinghamshire-gov-uk.s3.amazonaws.com/documents/Aylesbury_local_plan_L46JWaT.pdf
- **Ref. 6:** Buckinghamshire Council (2016), 'Buckinghamshire's Local Transport Plan 4'. Available online at: <https://buckinghamshire-gov-uk.s3.amazonaws.com/documents/local-transport-plan-4.pdf>
- **Ref. 7:** Buckinghamshire Council (2016), 'Highways Development Management Guidance: Managing the transport and travel impact of new developments'. Available online at <https://buckinghamshire-gov-uk.s3.amazonaws.com/documents/highways-development-management-guidance.pdf>
- **Ref. 8:** Ministry of Housing, Communities and Local Government, Ministry of Housing, Communities & Local Government (2018 to 2021) and Department for Levelling Up, Housing and Communities (2014), 'Travel Plans, Transport Assessments and Statements'. Available online at: <https://www.gov.uk/guidance/travel-plans-transport-assessments-and-statements>
- **Ref. 9:** Institute of Environmental Management and Assessment, (2023), "Environmental Assessment of Traffic and Movement"
- **Ref. 10:** National Highways, et al, Design Manual for Roads and Bridges LA 104: Environmental assessment and monitoring. Available online: <https://www.standardsforhighways.co.uk/search/0f6e0b6a-d08e-4673-8691-cab564d4a60a>

- **Ref. 11:** Buckinghamshire Council (2024), 'Public rights of way map'. Available online at: <https://prow.buckscc.gov.uk/standardmap.aspx>
- **Ref. 12:** Buckinghamshire Council (2024), 'Buckinghamshire Greenway Map'. Available online at: <https://www.buckinghamshire.gov.uk/parking-roads-and-transport/walking-cycling-and-wheeling/plans-to-improve-walking-cycling-and-wheeling/the-buckinghamshire-greenway/>
- **Ref. 13:** Sustrans (2024), 'National Cycle Network Map'. Available online at: <https://explore.osmaps.com/?lat=51.869452&lon=-0.878530&zoom=10.7822&style=Standard&type=2d&overlays=os-ncn-layer>
- **Ref. 14:** Crashmap (2024), 'www.crashmap.co.uk'
- **Ref. 15:** Department for Transport (2024), 'Road traffic statistics'. Available online at: <https://roadtraffic.dft.gov.uk/#6/55.254/-6.053/basemap-regions-countpoints>
- **Ref. 16:** Depart for Transport, SIAS Limited, et al, (2013) 'The NESAs Manual'.



rosefieldsolarfarm.co.uk